



Installation and Operating Manual

Stoves

LIVING FIRE
by SPARTHERM®

Preface - Quality philosophy

You have decided in favour of a SPARTHERM stove - thank you for your confidence in our company. In a world of abundance and mass production, we connect our name with the credo: "high technical quality combined with a contemporary style, as well as service for the sake of the customer's satisfaction and recommendation." We and our trade partners offer you first-class products that are emotionally moving and also engender feelings of comfort and security. To ensure this, we encourage you to read the operating manual carefully so that you can become familiar with your stove and its accessories quickly and thoroughly. In addition to information on use, these instructions also include important details on care and operation to guarantee your safety and to protect the value of your stove as well as useful tips and guidance.

Moreover, we show you how you can operate your stove in an environmentally responsible manner. For further enquiries, please contact your specialist dealer.

We hope you enjoy your new stove.

The SPARTHERM team

OVERVIEW OF INSTALLATION AND OPERATING MANUAL // STOVES

1. General instructions	4	3.3 Type plate	26	6.4 Cleaning the water heat exchanger SENSO M H ₂ O / PIKO H ₂ O	35
1.1 Certified quality	4	3.4 Operation of the water heat exchanger Senso M H ₂ O / PIKO H ₂ O	26	7. Troubleshooting	37
1.1.1 Scope of delivery	4	4. Combustion	27	7.1 Water heat exchanger SENSO M H ₂ O / PIKO H ₂ O	39
1.1.2 Damage while in transport	5	4.1 Initial commissioning	27	8. Disassembly	40
2. Assembly instructions	5	4.1.1 Combustion air regulation	28	8.1 Safety instructions for disassembly	40
2.1 Basic installation requirements	5	4.2 Heating-up / firing	28	8.2 Dismantle unit	40
2.1.1 Installation site	5	4.2.1 Adding wood	29	9. Disposal	40
2.1.2 Multiple configuration	6	4.2.2 Hourly wood feed quantity	30	9.1 Dispose of packaging	40
2.2 Transport and alignment aid	6	4.3 Controlling heat output	30	9.2 Dispose of the appliance	41
2.3 Installation/assembly	6	4.4 Room heating capacity / indoor climate	30	10. Appendix	41
2.3.2 Combustion air supply	9	4.5 Heating in the shoulder seasons/during unfavourable weather conditions	30	10.1 Accessories	41
2.3.2.1 Room-air-dependent	9	4.6 Chimney fire	31	10.2 Declarations of conformity	41
2.3.2.2 Separate combustion air supply	10	5. Fuel	31	11. Technical data	41
2.3.2.3 Room-air-independent	13	5.1 CO ₂ Neutrality	31	12. Final comment	41
2.3.3 Fire safety	13	5.1.1 Wood storage	32	13. Commissioning protocol	46
2.3.4 Cut-off device	18	5.2 Your contribution to environmental protection	32		
2.3.5 Connecting piece	18	6. Cleaning and care	32		
2.3.6 Installing the heat storage stones on top	18	6.1 Cleaning the combustion chamber/cladding parts	32		
2.3.7 Installation of the water-bearing components of the SENSO M H ₂ O / PIKO H ₂ O	19	6.2 Combustion chamber lining	33		
2.3.7.1 Connections of SENSO M H ₂ O / PIKO H ₂ O	19	6.3.1 Lubrication manual for door latches with Smartclose	34		
2.3.7.2 Basic requirements for installation of H ₂ O	19	6.3.2 Maintenance of the water heat exchanger SENSO M H ₂ O / PIKO H ₂ O	34		
2.3.7.3 Thermal discharge safety device (TAS)	20	6.3.3 Venting the water heat exchanger SENSO M H ₂ O / PIKO H ₂ O	35		
2.3.7.4 Thermal pump controller	21				
2.3.7.5 Electrical connection	21				
2.3.7.6 Integration in a heating system	22				
2.3.7.7 Return flow temperature boost	24				
3. Operating Manual	24				
3.1. General information on operation	25				
3.2 S-Function of the rotary-base	26				

1. GENERAL INSTRUCTIONS

Please consult your district master chimney sweep before assembling and installing the stove. He will advise you of building law regulations, the suitability of your chimney, and will conduct the acceptance procedure for your stove. The chimney calculation is executed in accordance with DIN EN 13384 using the set of values specified in this manual.

Important for small children, elderly or infirm persons: As is the case with all other heating devices, it is expedient that you attach a protective fixture for these groups of persons, as the view pane and the cladding parts of the stove can become extremely hot!

→ Danger of burn injuries! ←

Never touch the stove when the fire is burning or has just been extinguished! The stove should never be operated for an extended period of time unattended.

The enclosed heat protection glove is exclusively designed to activate the operating handle and the “cold hand”. The glove is not fire-proof!

National and European standards, the respective state-specific and local directives and regulations, and the respective firing installation ordinance of the German Federal State, must be complied with for setup and operation of your stove and for the connection to the chimney.

The stove must always be operated with the door closed. Modification of the closing device is prohibited!

*Important: The glove provided serves only as thermal protection and is not fireproof.

1.1 CERTIFIED QUALITY

OUR STOVES ARE TESTED IN ACCORDANCE WITH DIN EN 13240. DECLARATION OF PERFORMANCE IS AVAILABLE AND CAN BE VIEWED AT WWW.SPARTHERM.COM

These stoves are equipped with a self-closing fire door which means the door is only opened when the fireplace has to be serviced (e.g. to clean the combustion chamber or add more fuel). For safety reasons, the closing mechanism must not be tampered with; furthermore, any such action would render the warranty and operating licence null and void. The guarantee and operating licence are also rendered invalid if the customer modified the technology of any other area of the stove.

1.1.1 SCOPE OF DELIVERY

- Fireplace made of Vermiculite / Schamotte
- Primary and secondary air supply
- Pull-out ash pan or ash box and grate (not all models)
- Self-closing fire door with high-temperature-resistant ceramic glass.
- Insulated glove*
- Rating plate („3.4 Type plate“ on page 26)
- Supplied pre-assembled in transport-friendly disposable cardboard packaging
- Heat storage stones (only on SENSO L (optional))
- Pump thermostat, thermal discharge safety device ¾", bleeder (only on SENSO M H₂O, PIKO H₂O)
- Integrated cleaning system with control lever (only on PIKO H₂O)

1.1.2 DAMAGE WHILE IN TRANSPORT

Immediately on arrival, please check the goods delivered (visual inspection). Note down any possible damage on your delivery note and then please inform your stove fitter. Protect the visible elements of the stove from soiling and damage during installation. Only permitted and sufficiently strong transport aids may be used to transport the stove.

The following points must be noted to ensure safe and problem-free transport:

- It should be shipped in an upright position or slightly tilted on its back!
- Sack trucks used as a transport aid may only carry the stove from the back.

2. ASSEMBLY INSTRUCTIONS

The assembly and installation of your stove must be carried out by a specialist. Please consult your district master chimney sweep before assembling and installing the stove to clarify the suitability of the chimney system and the installation site, and also when having any further questions.

2.1 BASIC INSTALLATION REQUIREMENTS

For installation, connection and operation of the stove, all relevant national and European standards, as well as local regulations (DIN, DIN EN, state construction ordinances, firing ordinances, etc.) must be complied with and applied! The list of regulations given below is not exhaustive.

In the UK all stoves must be fitted in accordance with UK local building and HETAS regulations. Appliances may only be commissioned by HETAS accredited installers. Only appliances registered with DEFRA may be installed in UK smoke controlled area.

FeuVo: Feuerungsverordnung (Firing Installation Ordinance) of the respective German Federal State

LBO: Regional building regulations and fire regulations of

LRV: (Switzerland)

1. BImSchV: Erste Verordnung zur Durchführung des Bundes-Immissionsschutzgesetz (First Ordinance on the Implementation of the Federal Emissions Control Act)

TROL: Technical Rules of Tiled Stoves and Hot Air Heating System Trade (ZVSHK)

DIN 1298 / EN 1856: Connecting flue pipes for heat generating systems

DIN EN 13240: Roomheaters fired by solid fuel

DIN 18896: Fireplaces fired by solid fuel Technical rules: for installation and operation

DIN EN 13384 Chimneys: Thermal and fluid dynamic calculation methods

DIN 18160-1/2: Chimneys/house chimneys

DIN 4751 / DIN EN 12828: Heating systems in buildings – Design for water-based heating systems

VDI 2035: Water treatment for heating systems

Art. 15a: B-VG (Austria)

Fireplaces may only be installed in rooms and places where the location, construction situation and type of utilisation do not lead to hazards. The floor area of the installation must be of a design and size so that the fireplace can be operated properly and as intended.

2.1.1 INSTALLATION SITE

Your stove must not be installed:

1. In stairways, unless they are in residential buildings with two or fewer flats.
2. In hallways with general access.
3. In garages.

4. In Fireplace systems in rooms or flats that are ventilated through ventilation systems or warm air heating through the use of fans, unless the safe operation of the stove is ensured.
5. In rooms in which highly combustible or potentially explosive substances or mixtures are processed, stored or manufactured in quantities that would be hazardous in the event of ignition or explosion Room air independent stoves can be placed in rooms, apartments or utilization units of comparable size from which air can be sucked out using fans such as ventilation or hot air heating systems. The condition is that the vacuum-capable equipment cannot create a vacuum > 8 PA.

2.1.2 MULTIPLE CONFIGURATION

Multiple use of the chimney in accordance with DIN 18160 is possible because the stove has a self-closing fire door (A1). All fireplaces connected to a chimney must also be approved for multiple use!

2.2 TRANSPORT AND ALIGNMENT AID

The Spartherm stoves Moro with integrated transport and alignment aid give you the possibility to move the stove to the installation location with little effort and be able to perform the alignment quickly.

To do this, it is necessary to fully screw in the adjustable feet set into the lower wood compartment to align the stove.

After screwing in the feet, the entire weight load of the stove is supported by the transport casters set into the base. Now it is possible to move the stove back and forth.

Please ensure that the fitted natural stone elements do not move or fall off



Moro

the stove! After positioning, unscrew the adjusting feet and ensure the stove is standing securely.

Attention! The transport and alignment aids may only be used on a stable subfloor. Soft, delicate floors can be damaged by the high surface pressure of the transport casters!

2.3 INSTALLATION/ASSEMBLY

Your stove must be installed on floors with sufficient load-bearing capacity. Please observe the overall weight. The load-bearing capacity may have to be ensured by a sufficiently thick board (weight distribution).

Observe the necessary measures for fire protection in the floor area when choosing the installation location. („2.3.3 Fire safety“ on page 13)

Stability

Stoves with an upright design and fitted heat storage stones must be secured against unintentional tilting because of their top-heaviness.

The stove is placed on the floor in compliance with the safety distances („2.3.3 Fire safety“ on page 13) and aligned horizontally. The feet are adjustable in height.

Flue pipe elbow kit

Install the stove with the flue pipe bend set that we offer and refer to the following for the stove-specific connection height dimensions.

Flue pipe elbow kit, colour version				
Order no.	Unpainted	Black	Titan	Pearl
	-	1017770	1054844	1017771

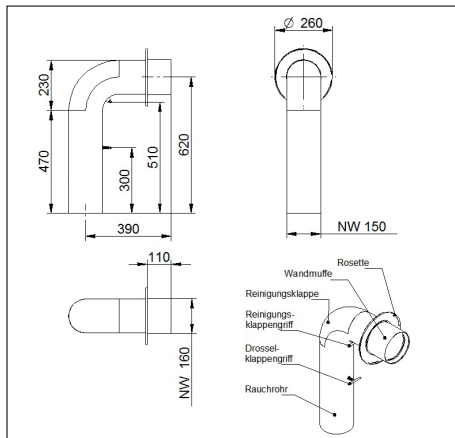

Fig. 1a

Dimension A: Flue pipe connection height with discharge to the back

Dimension B: Flue pipe connection height with use of the flue pipe bend set

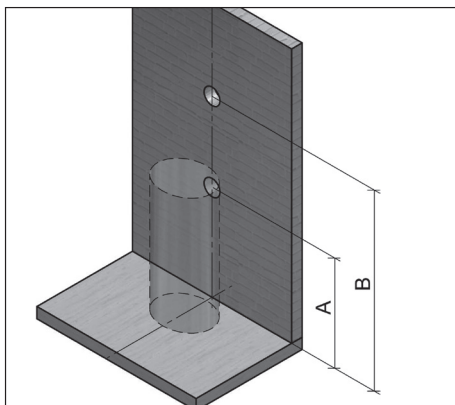

Fig. 1b

Stove	Bore \varnothing 150 mm	
	A (mm)	B (mm)
Sino		
Sino L	1085	1838
Sino City	1085	1844
Moro	1070	1844
Senso		
Senso S	916	1639
Senso M H ₂ O	1157	1906
Senso L	1087	1838
Senso L klassik	1087	1838
Senso L fashion	1087	1838
Sento		
Sento	1065	1814
Piko		
Piko S / Piko S steel	973	1730
Piko S steel mit Holzunterfach	1255	2012
Piko L	1113	1852
Piko Frame 1.1-1.12	1227	1984
Piko Frame 2.1-2.12	1272	2029
Piko Frame 3.1-3.12	1272	2029
Piko Frame 4.1-4.12	1227	1984
Cubo		
Cubo S	973	1730
Cubo L	1113	1852
Cubo L style	1143	1882
Lungo		
Lungo	1466	1904
Trico		
Trico S	1355	2087
Trico L	1355	2087

The connection measurement of rotatable unit designs differs by +10 mm.

2.3.1 CHANGING THE FLUE GAS CONNECTION DIRECTION

The stove is prepared for the flue gas connection at the top when delivered. Depending on the model, the flue gas connection position can be changed so that it is aligned to the back, to the side or around corners. Follow these installation steps when changing the flue gas connection position:

Changing the flue gas connection direction from the top to the back using the example of the Senso S

Installation from the top to the back

Remove the top plate (A) (Fig. 1) of the stove carefully and place it in a protected place. When removing the top plate, ensure that the fitted dummy cover (B) (Fig. 1) does not fall and gets damaged. Depending on the model, the top plate of the stove must be removed either upwards in advance or unlocked by parallel displacement to the front (model Stovo).

In stoves with fitted heat storage stones (for example Fig. 2) or convected air regulation (Fig. 3), these components must be removed “2.3.6. Installing the heat storages stones on top” on page 18.

After removing the top plate the flue gas connection piece (C) (Fig. 4) bolted onto the stove is visible. Remove these by loosening the internal hexagonal bolts (SW 13). Now remove the dummy cover (D) (Fig. 5) on the back of the covering panel for feed-through of the flue gas pipe. Depending on the model, the perforation for this must be broken through or 2 fixing screws loosened.

The only visible dummy cover (E) (Fig. 6) must be unscrewed using the internal screws (SW13) and replaced with the previously removed flue gas outlet (C) (Fig. 4). Fit the removed dummy cover (PE) onto the upper flue gas outlet in order to close this (Fig. 7) (screw connection SW13). Make sure that the sealing elements are correctly positioned under the

dummy cover and the flue gas outlet and ensure a tight seal. After screwing in tight, fit the optional storage elements and convected air gate to prevent airflow in reverse order and fit the lining elements (Fig. 8).

Note: The installation steps may be different depending on each stove model.

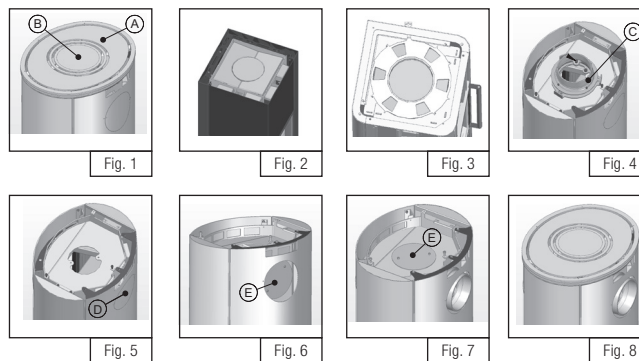

Special notes on the Piko H₂O model

The Piko H₂O model has gas evacuation to the side and to the top in addition to the option of connecting the connecting piping around a corner. If the installation situation of the Piko H₂O stove has been decided already during the planning phase, it is possible to order the stove with preassembled matching flue gas outlet from the factory.

If the orientation of the flue gas outlet on site has to be changed, please proceed as follows:

Installation from the top to the back/side

The flue gas outlet can be connected to the back in three different positions:

Carefully remove the top plate (A) (Fig. 9) of the stove and place it in a protected place. When removing the top plate, ensure that the fitted dummy

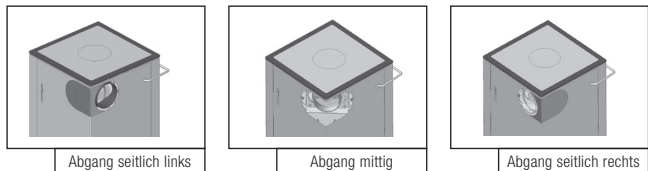

cover (B) (Fig. 10) does not fall and get damaged.

After removing the top plate, the flue gas connection piece (C) (Fig. 10) bolted onto the stove body is visible. Remove it by loosening the internal hexagonal bolts (SW 13). Then, remove the back cover plate (Fig. 10) using the screw connection. A blanking plug for the flue gas outlet to the back/side is visible (E) (Fig. 11) behind the cover plate. Unscrew this.

Now fit the flue gas connection pipe depending on the desired orientation to the right/left side or straight back. For the right/left side connection type, a separate connecting piece is supplied with the Piko H20 stove (Fig. 13). The top connecting piece is used for the back connection type. Ensure that the underlying caulking strip is placed correctly and seals tightly.

The removed dummy cover (E) is screwed in place as shown in (Fig. 12) and seals the flue gas outlet at the top.

Finally, close the open cladding openings at the back of the stove with the enclosed cover plates and fit the top plate (Fig. 14).

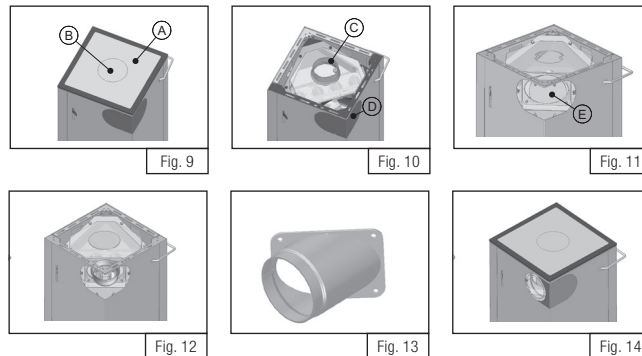

2.3.2 COMBUSTION AIR SUPPLY

The combustion air can be supplied in accordance with „2.3.2.1 Room-air-dependent“ and „2.3.2.3 Room-air-independent“ in different ways.

2.3.2.1 ROOM-AIR-DEPENDENT

Your stove draws the combustion air from the installation area (room air dependent operation). Ensure that the installation area is adequately supplied with fresh air (more details in the country-specific FeuVO, DIN 18896, the technical regulations, etc.). The fresh air supply must be checked by the installer and the operator. When operating several fireplaces in a single room or linked space, ensure that sufficient air is available for complete combustion! It is possible that there is not a sufficient supply of fresh air if the windows and doors are sealed (e.g., in combination with energy saving measures). As a result, the ventilation of the tiled stove can be affected. This can adversely affect your well-being and, potentially, your safety. If necessary, an air valve must be installed near the pellet stove for the additional supply of fresh air, or a combustion air line

must be routed outwards („2.3.2.2 Separate combustion air supply“) or in a well-ventilated room (except for the heating room). In particular, ensure that the necessary combustion air pipes are open during the operation of the fireplace insert. Simultaneous operation with a ventilation system (e.g. extractor hood, bathroom fan, etc.) in the same room or connected space can adversely affect the function of the stove (to the point of smoke or flue gas accumulating in the living room, despite the firebox door being closed). It is therefore prohibited to operate appliances of this kind simultaneously with a fireplace without first taking appropriate precautionary measures („2.3.2.3 Room-air-independent“).

2.3.2.2 SEPARATE COMBUSTION AIR SUPPLY

The stove can be supplied with combustion air separately. The separate combustion air connection can be connected to the rear side or from below. The connecting piece is preassembled and the cladding must be opened accordingly. When connecting a pipe connection to the combustion air neck, the combustion air can be supplied to the stove from the outside or from other rooms such as the cellar. When connecting the stove to a combustion air line, the TROL instructions (technical rules), the DIN 18896, etc. must be observed and applied.

In particular, ensure that the dimensions of the pipes are adequate! When using the rotary base, the connection must be designed as durable and flexible! The ability for it to rotate must not be affected.

The combustion air openings and lines must not be closed or blocked other than if it has been ensured that the fireplace can only be operated with opened fastening by special safety equipment. The cross-section must **not** be narrowed by a fastening or a grille. This measure is not necessary with LAS chimneys. A shut-off valve must be installed, where the combustion air feed line runs outside

the building. In doing so, it must be possible to easily determine the shut-off valve setting from outside of the connecting line. In this version, the pipe should be insulated to prevent condensation. The pipe should be positioned, so that any condensation formed can run out of the pipe and any water or other foreign substances from outside cannot get into the stove. In accordance with regulations, combustion air piping crossing a fire wall in buildings with more than two storeys must be established in such a manner that smoke or fire cannot be transmitted to other floors or fire compartments. Country-specific and local fire safety regulations must be observed!

Supply air connector with connection sleeve for stoves

Compatible with the following stoves:

Piko/Cubo/LH₂O
Senso S/L-RLU

All the non-listed types are equipped with a common duct.

Assembly:

To connect the separate combustion air to the stove, the stove features a connector which can be screwed onto either the rear or side.

This connection option is located at the bottom as standard but can be changed to suit the situation. (Also see the assembly and operating instructions for the stove).

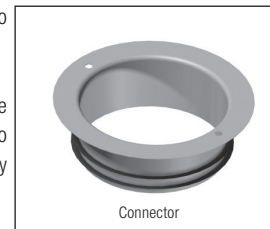

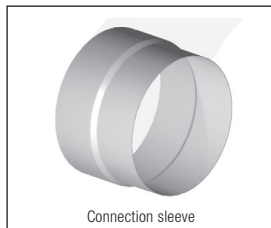

The on-site combustion air channel is connected to the stove using the connection sleeve in the combustion chamber. The sleeve must be attached securely to the channel using a hose clamp (not included in the scope of supply).

Now push the sleeve onto the connector. The connection sleeve and connector are pushed onto each other without additional fixation. The sealing lips of the connector ensure a safe, air-tight fit.

The description below refers to connection of the supply air to the rear:

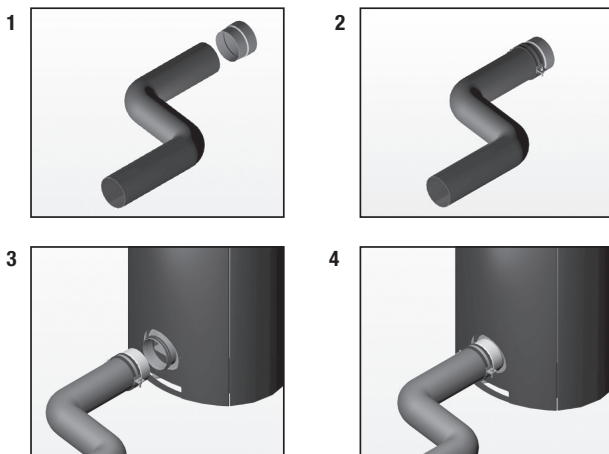

1. Push the connection sleeve into the flexible pipe.
2. Fix in placing using a hose clamp.
3. Push the connection sleeve with flexible pipe onto the assembled supply air connector.
4. And you're ready to go!

Spartherm Quick Coupling - SQC coupling Compatible with the following stoves:

- Senso S
- Piko / Cubo S/L

The installation location of the stove must be determined according to the specified technical data for the supply channel / hole. For direct wall mounting, the combustion air and flue gas connection must be prepared on one level. The stove is delivered with the fitted SQC coupling and the adjustable feet extended. In this condition, the connecting piece is in the air, and there is no contact to base unit. Therefore, the stove can be transported as usual with the normal tools (e.g. sack truck).

Example of Senso S:

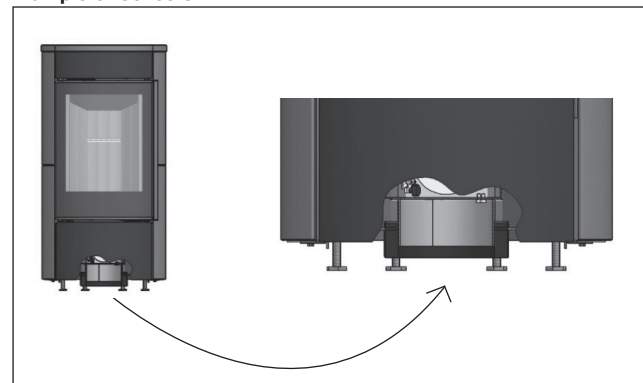

Transport position with SQL coupling

Fig. 15

Assembly sequence

1. Position the stove with the extended adjustable feet in its final position.

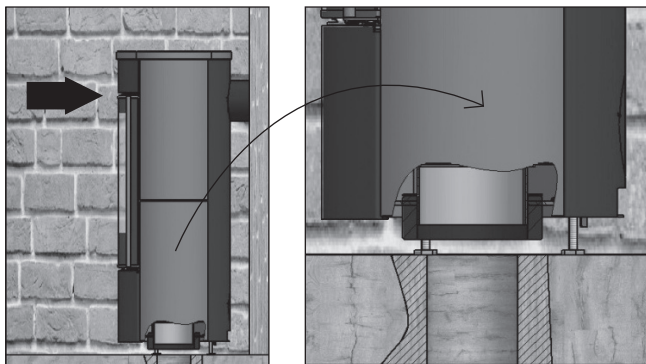

2. Screw in the adjustable feet to adjust the stove to its nominal height. When lowering it, the SQC connecting piece makes contact with the base unit and encloses the supply opening on the site side.

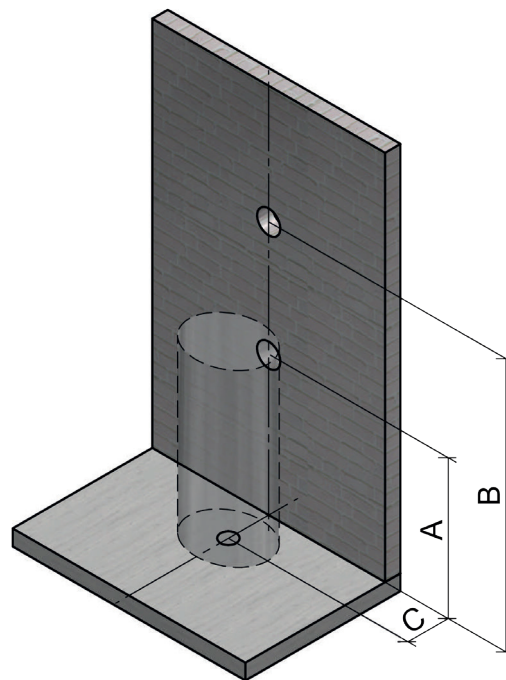
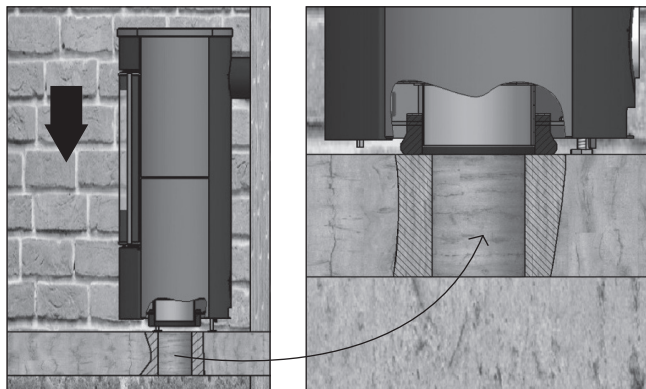

Companion dimensions of a stove with SQL coupling

For **dimension A** and **dimension B**, see point „2.3 Installation/assembly“ on page 6.

Dimension C:

Distance from the mounting wall to the centre air supply hole. Ensure the clearances of the flue pipe connection to the chimney are complied with!

Stove	Date of construction	Order no.	C (mm) Bore Ø 100 mm	
			for a combustible mounting wall	for a mounting wall that is not to be protected
Senso S	ab 11/2014	1033724	308	258
Cubo S	ab 07/2020	1033728	303	252
Cubo L		1033726	309	259
Piko S	ab 11/2014	1033728	302	252
Piko S steel		1033728	302	252
Piko L		1033726	309	259

2.3.2.3 ROOM-AIR-INDEPENDENT

The RLU stoves have been developed for use with residential ventilation systems for a vacuum range of up to 8 Pa in the installation area and can be operated without additional safety equipment. The combustion air must be supplied in airtight lines from the outside or via an LAS system to the device for room-air-independent operation without fail. To do this, the combustion air duct must be permanently sealed to the combustion air neck (connection type back/side or bottom) of the stove.

When connecting the RLU stove to a combustion air line, the TROL instructions (technical rules), the DIN 18896, etc. must be observed and applied. In particular, ensure that the dimensions are adequate!

Country-specific and local fire safety regulations must be observed! Make sure that the pipes are always airtight.

2.3.3 FIRE SAFETY

The handover inspection of your stove before commissioning is performed by the chimney sweep responsible. You can also advise the chimney sweep prior to installation about installation conditions on site, and can provide advice on how to install your stove properly.

General Information on fire prevention

Stoves are heat generators and are subject to regulations and necessary measures for fire protection. The fire regulations and the recommended minimum clearances of the device must be observed even when selecting the installation site. **Basically, a minimum wall clearance of 5 cm to the back wall must be adhered to. For reasons of safety and fire protection, larger clearances must be ensured to protected walls or combustible materials.**

In the following table on page 17, the permissible clearances are documented according to the type of the stove and the type of on-site mounting wall. Using the diagrams (Fig. 19-23), match the mounting situation, taking into account the specified distances that need to be complied with.

Follow the instructions for fire protection during installation and ask your local chimney sweeper.

- Mounting walls that are **non-combustible or not to be protected** are suitable to withstand permanent exposure to temperatures > 85°C thanks to their structure and their material type.
- Mounting walls that are combustible or to be protected (e.g. timber frame construction) must be protected from temperatures > 85°C.

Before installing the stove, it is necessary to evaluate the mounting walls. If the type of mounting wall cannot be clearly assigned, a specialist (chimney sweep) must be consulted.

- Wallpaper as wall coverings in accordance with DIN 4102-1 are non-combustible components and do not require special precautions for fire protection. Ensure here that the underlying structure of the wallpaper (e.g. timber frame construction) is very easily ignited or must be protected and appropriate precautions must be taken!
- Ensure that the specified minimum clearances to the back and side wall must be adjusted for the rotary devices.
- Ensure that the minimum clearances from chimney connecting piece to combustible components are adhered to (see „2.3.5 Connecting piece“ on page 18).
- Combustible objects must not be located at a distance of **50 cm** above the fireplace!

Floor coverings near the stove

Floors in front of the combustion chamber opening have to be protected from combustible materials by a board made of non-combustible materials. The board must extend over at least 50 cm to the front and at least 30 cm to the side (Fig. **19-23** C + D) (measured from the combustion chamber opening or viewing window)!

No combustible components, furniture, curtains or decorations may be placed in the area of direct radiant heat of the fire door or inspection glass. This distance may be reduced to 400 mm if radiation protection plates are installed between the fireplace and combustible structures on both sides.

Minimum distances to adjacent components

Depending on the view pane arrangement (see the following graphics) of your stove and the type of mounting walls, the distances from the table are to be adhered to.

The following describes

- Distance A as the minimum distance of the stove sidewall to the mounting wall
- Distance B as the minimum distance of stove back wall to the mounting wall
- Distance C as the area of direct radiant heat in front of the view pane (n) of the stove

Special note on minimum side distance

Minimum side distance (Fig. 17 (A)) describes the minimum distance from the stove to the side mounting wall and is valid from the back mounting wall to the beginning of the area of direct radiant heat (E) of the front panel. In stoves with curved front pane or a wide area of direct radiant heat, the minimum wall distance (A) must be adjusted to the extending area of direct radiant heat.

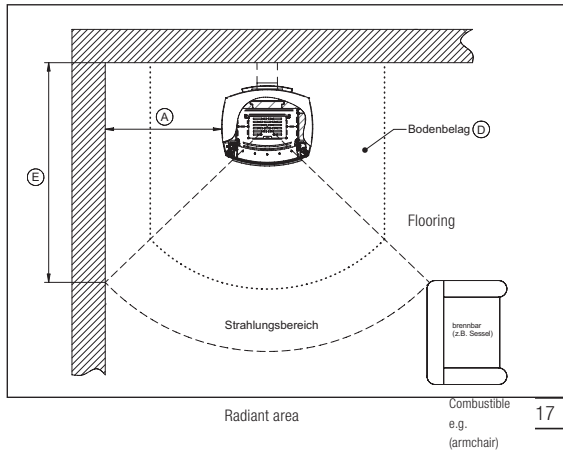

Determining the area of radiant heat

To layout the area of direct radiant heat of the stove, put a measuring instrument (ruler or measuring tape) on the surface of the view pane and determine the centre of the fireplace past the side door pillar (Fig. 18). In the resulting angle and the distance **A1**, there must be no combustible or components to be protected on the sides.

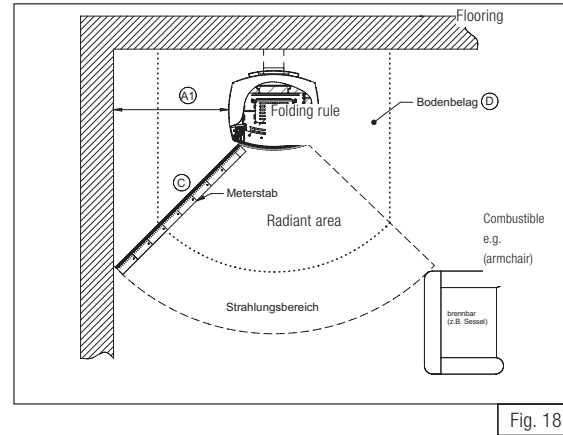

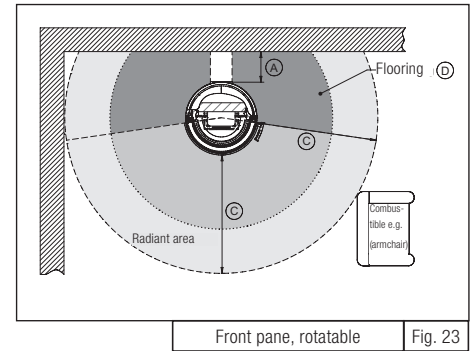
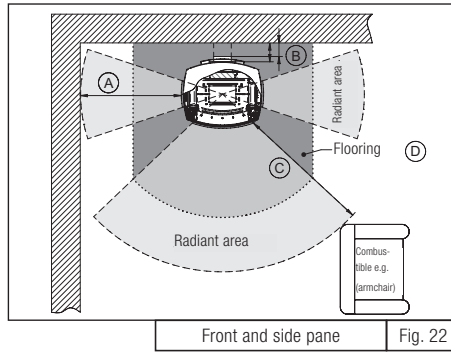
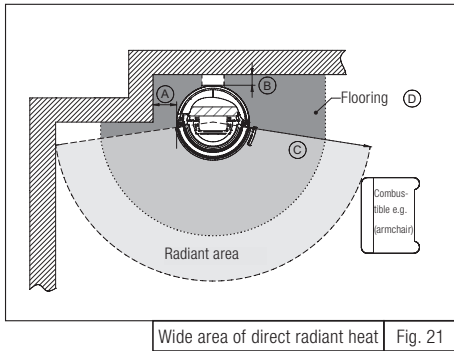
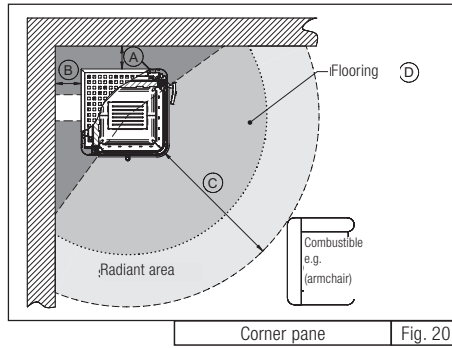
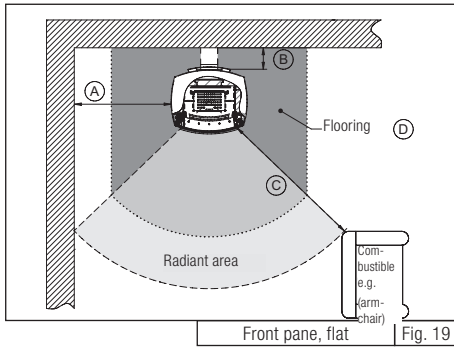

Stoves	Distance to side wall		Distance to back wall		Distance in the area of direct radiant heat of the pane(s)		Dimensions of the fire protection floor covering	
	A (cm)		B (cm)		C (cm)		D (cm)	
	Combustible	No protection required	Combustible	No protection required	Combustible	No protection required	In front of pane Side***	Distance (with round floor covering)
Piko S / Piko S RLU / Piko S steel	10	10	10	5	80	80	50 30	50
Piko L / Piko L RLU	10	10	10	5	80	80	50 30	50
Piko H ₂ O	10	10	10	5	80	80	50 30	50
Piko Frame	See separate instructions							
Cubo S / Cubo S RLU	10	10	10	5	80	80	50 30	50
Cubo L / Cubo L RLU	10	10	10	5	80	80	50 30	50
Cubo L style / Cubo L style RLU	10	10	10	5	80	80	50 30	50
Senso S**	47	20	10 *	5	80	80	50 30	50
Senso M H ₂ O	10	10	10	5	80	80	50 30	50
Senso L / Senso L RLU**	13	10	15	5	120	80	50 30	50
Senso L klassik / Senso L klassik RLU	13	10	10	5	120	80	50 30	50
Senso L fashion / Senso L fashion RLU	13	10	10	5	120	80	50 30	50
Sento	5	5	15	5	125	80	50 30	50
Sino L	13	10	10	5	120	80	50 30	50
Sino City / Sino City RLU**	13	10	10	5	120	80	50 30	50
Moro / Moro RLU**	35	20	20	5	140	80	50 30	50
Lungo	6	5	6	5	120	80	50 30	50
Trico S	40	20	10	5	Vorne: 80 Seite 40	80	50 30	50
Trico L	40	20	10	5	Vorne: 80 Seite 40	80	50 30	50

* The distance is only valid in conjunction with a radiation protection plate on the top plate, which is fitted behind the vertical flue gas pipe.

** The distance to combustible lateral construction elements is based on the heat emissions through the front glass panel.

*** The floor covering must extend at least 50 cm to the front and at least 30 cm to the side (measured from the combustion chamber opening or viewing glass)!

2.3.4 CUT-OFF DEVICE

Exhaust systems must be created in accordance with the Technical Rules of Tiled Stoves and Hot Air Heating System Trade (TROL). Stoves should have a shut-off device in the exhaust gas flue. These devices must not be self-closing and must not be positioned such as to prevent or hinder the inspection and cleaning of connecting pipework. The position of the shut-off device must be visible from the outside, e.g., from the position of the operating handle. Shut-off devices may only be installed in the exhaust manifold or collecting pipe, the flue gas pipe stub or the pipeline connecting piece.

2.3.5 CONNECTING PIECE

Your stove is connected to the chimney with \varnothing 150 mm/ \varnothing 160 mm connecting pieces made of steel plate which is at least 2 mm thick. These connecting pieces must satisfy the requirements specified in DIN 1298 and DIN EN 1856-2, and must be connected to the chimney system in accordance with the requirements specified in DIN 18160 or the country-specific regulations. It must be ensured that the flue gas pipe is installed in the shortest possible route upwards towards the chimney. To achieve this, ensure that the flow of flue gas is redirected as few times as possible. Ensure that the flue pipe is stable; where appropriate, the flue pipe may need to be secured with brackets. If the flue leads through a combustible wall or is located close to any combustible components, the flue is to be insulated according to the respective regulations. The connecting line must always be mounted in such a manner that it is possible to clean the connecting line at any time. This must be ensured through a sufficient number of cleaning openings. If the stove is rotatably mounted, the connecting pipe must be installed so that no negative effects occur on the fixing. The flue pipe must not also turn. The minimum distance from the chimney connecting piece to any combustible components can increase the distance from the stove to combustible components, in accordance with the manufacturer specifications for the flue pipe. The specified minimum distances to combustible components as stated in these instructions refer to the fireplace and must be adjusted if necessary („2.3.3 Fire safety“ on page 13).

Ensure that a cleaning opening is located above the flue pipe connection with gas evacuation to the top.

2.3.6 INSTALLING THE HEAT STORAGE STONES ON TOP

The heat storage stones delivered with your stove are packed separately due to their heavy weight. After the stove has been assigned its location in the installation space, you can begin with the installation of separate heat storage stones.

Senso L*/Senso L RLU*:

* Heat storage stones optional

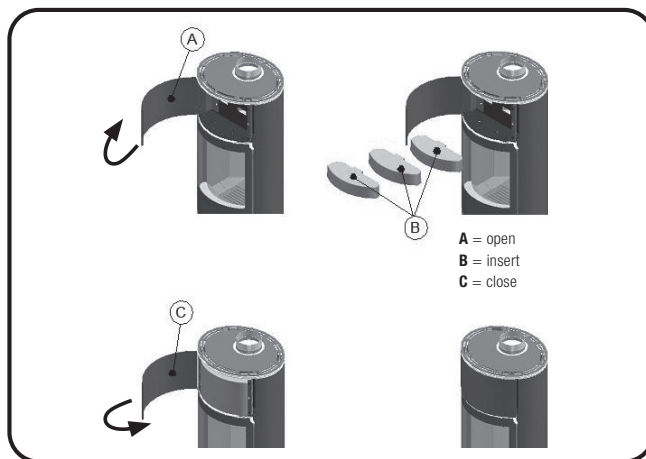

2.3.7 INSTALLATION OF THE WATER-BEARING COMPONENTS OF THE SENSO M H₂O / PIKO H₂O

Assembly of the water-bearing components, the necessary safety devices, temperature sensors and similar components must always be carried out by a specialised company. The Senso H₂O / Piko H₂O must be installed with all water-bearing components accessible and inspectable at all times!

The stove as well as all associated immersion sleeves, connectors, moulded components and pipes must be have the pressure checked prior to commissioning and checked for airtightness.

2.3.7.1 CONNECTIONS OF SENSO M H₂O / PIKO H₂O

The connections on the Senso M H₂O are on the rear and can be guided from the inside downwards as an alternative. The connections of the Piko H₂O are at the bottom and can be routed to the side or the back as an alternative.

The connections have transport caps and brass stops for transport purposes. This must be removed prior to installation. The connections are clearly labelled and must not be used other than for the specified purpose! In particular, the integrated safety device (safety heat exchanger) must not be used to heat water.

A flex attachment kit can be ordered for easy and quick connection of pipes in the floor and the internal connections. An installation template at a scale of 1:1 can be requested from us as a paper print-out. The installation template is valid only in combination with the flex attachment kit.

2.3.7.2 BASIC REQUIREMENTS FOR INSTALLATION OF H₂O

The Senso M H₂O / Piko H₂O must only be mounted in thermostatically protected systems in accordance with DIN 4751 or DIN EN 12828. All lines to the heating network must always be designed so that they can be detached (e.g. as threaded fitting).

Before the stove is placed in service, it must be filled and ventilated on the heating side (heating network) and water side (thermal discharge safety device, safety heat exchanger). After the filling process, check all hydraulic connections for leaks.

Connections Senso M H₂O (back view)

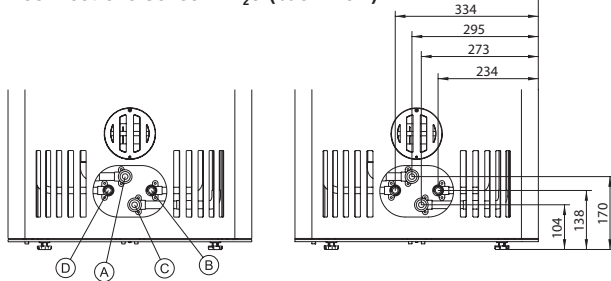

A = return 3/4" IG

B = inlet of thermal discharge safety device 1/2" IG

C = flow 3/4" IG

D = discharge of thermal discharge safety device 1/2" IG

Connections Piko H₂O (view from below)

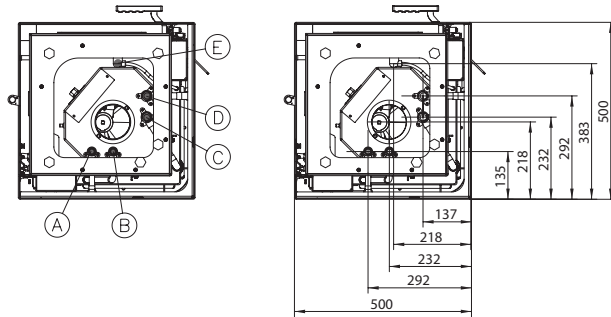

A = inlet of thermal discharge safety device 1/2" IG

B = discharge of thermal discharge safety device 1/2" IG

C = return 3/4" IG

D = flow 3/4" IG

E = bleeder 3/8"

Operation without a water-side connection results in irreparable damage and invalidates any warranty claims!

In the direct vicinity of the Senso M H₂O / Piko H₂O, a type-tested safety valve (identification letter H) with an activation overpressure of max. 3.0 bar must be mounted in the flow line. A shut-off possibility must not be integrated in the system between the safety valve and the Senso M H₂O / Piko H₂O. This could render the safety device inoperable. Moreover, all necessary safety devices must be integrated in the entire system in such a manner that safe operation is ensured. A separate safety valve must also be installed, if such a safety valve is installed at a different point in the entire system (comply with TRD 721!).

When installing, the instructions in the installation and operating manuals of the installed heating-related components/additive components must always be complied with!

2.3.7.3 THERMAL DISCHARGE SAFETY DEVICE (TAS)

Since the heating of the Senso M H₂O / Piko H₂O is not automatic and can be quickly switched off, according to DIN 4751 – Part 2 and DIN EN 12828, the stoves are equipped with a thermal discharge safety device. For this, a safety device (safety heat exchanger) is integrated in the Senso M H₂O / Piko H₂O to prevent overheating. This safety device must not be used as a water heater. The thermal discharge safety device is not preassembled for safety reasons during transport and installation, but instead enclosed in the combustion chamber. During installation, it must be fitted to the marked connection. Then, use the adapter to screw the capillary line to the TAS. This has been tested and approved for a minimum throughput of 900 kg / h of water.

The following instructions must always be complied with for the installation, so that the safety device can function:

- At the cold water inlet, a flow pressure of at least 2 bar must be available. This pressure must be constantly ensured. This is because, operation on a mains-voltage-dependent domestic water supply is not permitted!
- Minimum water throughput of approx. 900 L/h must be ensured. It must not be possible to shut off this supply line!
- It must be ensured that cold water (5-20°C) is available at any time. Domestic water supplies is not included in this.

All safety-relevant components must be integrated in the system in such a manner that function and leak-tightness can be checked at any time. The discharge of the thermal discharge safety device must be designed in such a manner that a check (e.g. via a drain with siphon) can take place at any time. Before commissioning, the cold water pipe must be purged! This flushes out dirt, which would otherwise impact closing of the TAS. The manufacturer's instructions for the TAS must be observed.

2.3.7.4 THERMAL PUMP CONTROLLER

For optimum control of the circulating pump, a thermostat is integrated in the lower compartment. This ensures that the circulating pump starts only with adequate water temperature (> 60°C). The boiler control or similar devices can be used as a controller if a switch-on temperature of the pump between 60°C and 68°C is guaranteed. The maximum contact load of the thermal pump control at alternating current 250 V AC is approximately 10 (2.5) A. The factory setting of the thermostat has been set to about 62°C. When the switch-on and switch-off temperature of the circulation pump of return riser is reached, or undershot, the required water temperature in the water heat exchanger of the Senso M H₂O / Piko H₂O is determined. Optionally, if

conditions so require, the temperature can be adjusted by the installation company. To do this, the housing cover of the pump thermostat, which is located in the lower compartment of the stove, must be removed. After removing the cover, the temperature range can be changed by adjusting the red screw.

Please note: If water temperatures fall below 60°C, there is an increasing risk of temperature falling below the dew point level! This can result in the formation of shining soot. Furthermore, this shortens the cleaning interval. We do not recommend that the switch-on temperature is set below 60°C, but also not set at more than 68°C.

2.3.7.5 ELECTRICAL CONNECTION

The entire electrical installation of the individual components of the heating system must only be executed by an authorised specialised company. All electrical installations are to be carried out as per the VDE regulations (e.g. VDE 0105, VDE 0116, VDE 0100, etc.) and the technical connection conditions of the local power company.

On the Senso M H₂O / Piko H₂O, only carry out the electrical installation from thermostats to the pump of the return flow temperature riser („2.3.7.7 Return flow temperature boost“ on page 24) and to domestic power grid (**see figure**). The temperature-resistant connection line is about 3.0 m long and already stuck to the thermostat.

The function of the thermostat switch is to be able to test the hot water (e.g. from kettle) and the thermometer. The cladding must be removed to do this.

2.3.7.6 INTEGRATION IN A HEATING SYSTEM

Please note: The Senso M H₂O / Piko H₂O must only be installed after detailed planning of the overall heating system in accordance with the relevant rules of technology and the safety standards. Proper configuration of the pumps, fittings, pipeline, buffer tank and the safety components is the responsibility of the planning firm and/or of the company in charge of installation.

For heating lines, we recommend a minimum nominal diameter, copper pipe of 22 x 1.0 mm, or 3/4" for steel pipe.

With cold water pipes, a pipe diameter (copper pipe) is 15 x 1.0 mm and a flow pressure of 2.0 bar is sufficient for safe operation.

However, dimensioning of this pipework must be carried out by the specialist company in charge, taking due account of on-site conditions.

Integration of the Senso M H₂O / Piko H₂O can be carried out based on the **diagram** on the next page.

A buffer tank must be connected up. German legislation 1st and 2nd BImSchV mandates the design of volume for this buffer tank. This regulation specifies that for each kW water capacity, at least 55 liters of buffer volume must be kept.

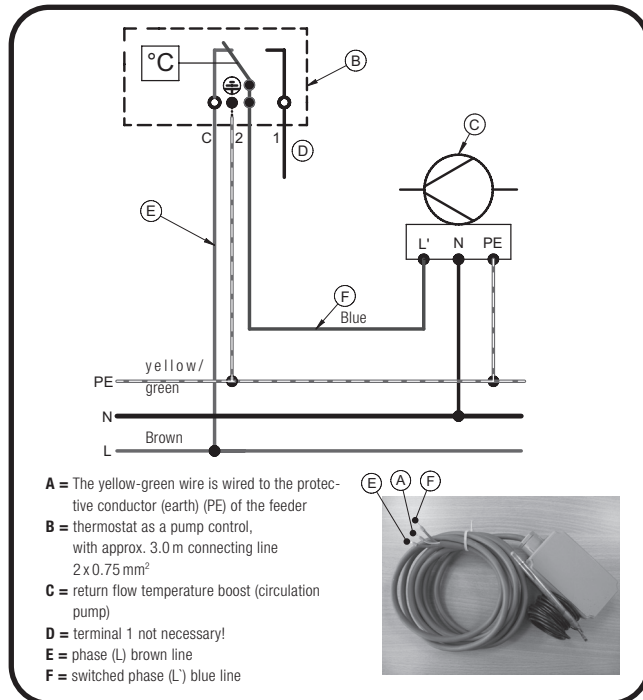

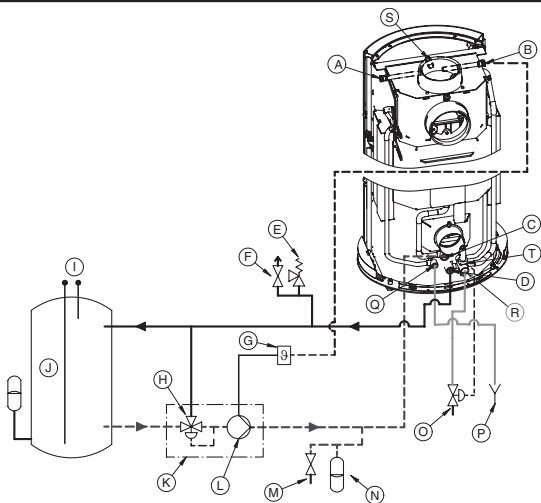

- A** = temperature sensor for thermal discharge safety valve
- B** = temperature sensor for thermostatic switch ½" IG
- C** = return ¾" IG
- D** = flow ¾" IG
- E** = safety valve 3 bar
- F** = bleeding
- G** = thermostatic switch - pump
- H** = return riser
- I** = connection for heating system
- J** = buffer reservoir
- K** = return flow temperature boost
- L** = circulation pump
- M** = filling and draining fitting
- N** = diaphragm expansion tank
- O** = thermal discharge safety device
- P** = free discharge in e.g. sewer network
- Q** = "discharge" safety heat exchanger ½" IG
- R** = "inlet" safety heat exchanger ½" IG
- S** = bleeding ¾"
- T** = thermal discharge safety device

Senso M H₂O

For the Senso M H₂O, these are: 5.0 kW x 55 litres / kW = 275 litres.

Piko H₂O

For the Piko H₂O, these are: 4.6 kW x 55 litres / kW = 253 litres.

Since these are not normal market sizes, the next larger buffer tank should be chosen with 300 or 500 litre capacity.

The following sample calculation can be helpful for dimensioning the buffer tank:

The following assumptions have been made in this regard:

Senso M H₂O

- Size of the buffer tank: 750 l (approx. 750 kg water)
- Water temperature in the buffer tank at the beginning: 30°C
- Water temperature in the buffer tank at the end: 60°C
- Temperature differential 30°C (corresponds to 30 K)
- Water is not taken from the tank during heating by the Senso M H₂O!

$$Q = cp \times m \times \Delta t$$

$$Q = 4,187 \frac{\text{kJ}}{\text{kg} \times \text{K}} \times 750 \text{kg} \times 30 \text{K}$$

$$Q = 94207 \text{ kJ}$$

Piko H₂O

- Size of the buffer tank: 500 l (approx. 500 kg water)
- Water temperature in the buffer tank at the beginning: 40°C
- Water temperature in the buffer tank at the end: 70°C
- Temperature differential 30°C (corresponds to 30 K)
- Water is not taken from the tank during heating by the Piko H₂O!

$$Q = cp \times m \times \Delta t$$

$$Q = 4,187 \frac{\text{kJ}}{\text{kg} \times \text{K}} \times 500 \text{kg} \times 30 \text{K}$$

$$Q = 62805 \text{ kJ}$$

This means: To heat up 750 litres of water in a buffer tank, from an assumed 30°C to 60°C, a theoretical heat quantity of 94207 kJ is required (losses or heat withdrawals in the system have not been taken into account). This heat quantity corresponds to approx. 26.2 kWh.

At an average assumed water power of approx. 5.0 kW of the Senso M H₂O, heat-up of the entire buffer tank of 750 litres of water takes approx. 5.25 hours. This calculation is based on the uniform heating of the entire tank volume.

For a sensible design of the heating system, the hot water should be stacked in buffer tanks. e.g. in a stratified storage tank! As a result, after only a short heating-up period, hot water is available and the heat utilization can begin shortly after circulation starts in the Senso M H₂O / H₂O Piko. In this case, only the excess energy will be stored in the buffer tank, not the energy required for heating.

On extremely cold winter days, it is possible that the Senso M H₂O / Piko H₂O may also be in operation for approximately 12 hours. The amount of heat produced in the water meter corresponds theoretically to 60 kWh / 55 kWh. This amount of heat would be sufficient to heat about 1700 litres (from 30°C to 60°C) / 1575 litres (from 40°C to 70°C) are sufficient. As a rule, in such a situation heat is also continuously withdrawn so that overloading of the buffer tank (> 90°C) should not occur.

This means: To heat up 500 litres of water in a buffer tank, from an assumed 40°C to 70°C, a theoretical heat quantity of 62805 kJ is required (losses or heat withdrawals in the system have not been taken into account). This heat quantity corresponds to approx. 17.5 kWh.

At an average assumed water power of approx. 4.6 kW of the Piko H₂O, heat-up of the entire buffer tank of 500 litres of water takes approx. 3.8 hours. This calculation is based on the uniform heating of the entire tank volume.

2.3.7.7 RETURN FLOW TEMPERATURE BOOST

The Senso M H₂O / Piko H₂O must be operated with a return flow temperature boost. In operation, the flow temperature should be above 65°C and the return temperature at least 60°C. So that these temperatures are ensured, a circulation pump must be installed in such a manner that it only starts up if 62°C has been reached. To reduce the risk of undershooting the dew point temperatures, a controlled return riser must be installed. Here is where the control variable, this corresponds to the effective return temperature at the inlet of the water heat exchanger, is recorded and set to the desired value. We recommend the use of a return riser – riser of the type LTC 300 from ESBE, which is available as an option, or a comparable return temperature riser. Using other possible solutions (such as a four-way mixer valve) has not proven itself in practice and is therefore not recommended.

We can not accept any liability or guarantee for any stoppage (sooting, deposits, etc.) or corrosion damage on the water heat exchanger or chimney, etc., that is caused by a missing or malfunctioning return riser.

3. OPERATING MANUAL

Read these installation and operating instructions carefully before installing and starting up your stove. All objects must be removed from the combustion chamber (except for combustion chamber liner). Have your specialized dealer instruct you in the control and operation of the stove! National and European standards and local regulations for operating the fireplace must be observed!

3.1. GENERAL INFORMATION ON OPERATION

- Small children, elderly or infirm persons: As is the case with all heating devices, it is expedient that you attach a protective fixture for these groups of persons, as the view pane and the cladding parts of the stove can become extremely hot! **Danger of burn injuries!** Never leave these groups of persons unattended near the stove when a fire is burning or has just been extinguished! Make these individuals aware of these risks.
 - No combustible objects may be placed or laid on the free surfaces and the panels of the stove. Do not place items of clothing on the stove to dry. Racks for drying clothing may only be placed outside the radiation area!
 - The surfaces of your stove components (including the surfaces, the door, the door and operating handles, glasses, flue pipe) are quickly made hot by heat energy released during the combustion process. Do not attempt to touch these components without protection (i.e. heat-resistant gloves).
 - **The enclosed heat protection glove is exclusively designed to activate the operating handle and the “cold hand”. The glove is not fire-proof!**
 - The stove may only be operated with the fire door closed. The door should be kept in a cold state is always closed. Only open the door for firing, refueling and cleaning!
 - The fireplace must never be modified! In particular, never insert any installation components into the combustion chamber, combustion air passages or flue gas flue that have not expressly approved by Spartherm. Your fireplace warranty and operating permit will be rendered invalid by any fireplace modification that has not been approved.
- You may find that extractor hoods, ventilation equipment, etc. installed in the same room (or linked space) as your fireplace or stove have a negative effect on the operation of the Kaminofen (such as the release of smoke into the room). These devices should not be used at the same time as your fireplace or stove, without first ensuring that the necessary room heating system precautions have been taken. („2.3.2.3 Room-air-independent“)
 - In particular when operating several fireplaces in a single room or linked space, ensure that sufficient air is available for complete combustion!
 - This is a temporary fire area thus, longer continuous burning is not achieved by piling up the fire repeatedly. Continuous burning without piling up the fire in-between cannot be achieved even through withdrawal of the combustion air and is also not permitted. A longer heating period is achieved by repeatedly restoking the fire with suitable amounts of fuels.
 - Only non-combustible materials must be placed in the lower compartment of the cladding!

3.2 S-FUNCTION OF THE ROTARY-BASE

Installation of a rotary base can only be executed at the top and must be stated when ordering. This allows the stove to rotate by 90°, i.e. 45° each to the left and to the right (fig. 24).

To allow the Senso S stove to rotate, loosen the adjustment bolt/the stop (Fig. 27). This is located on the foot plate. Now you can turn the stove in the desired position. To fix the stove, turn the adjustment screw/the lock (Fig. 27) again.

On some models, the transport lock has to be removed in advance (Fig. 25). This is located at the rear at the bottom. To remove the transportation safety device, remove the cylinder head screw (Fig. 25) with a wrench size 5 hexagon key (this is included with the stove).

Finally, remove the transportation safety device (Fig. 26).

3.3 TYPE PLATE

The type plate is located both on your guarantee certificate, as well as on your stove at the back or under the ash drawer. It includes technical data and information. The type plate must not be removed as it confirms the testing of the stove and is required for the acceptance procedure and annual inspections by the chimney sweep.

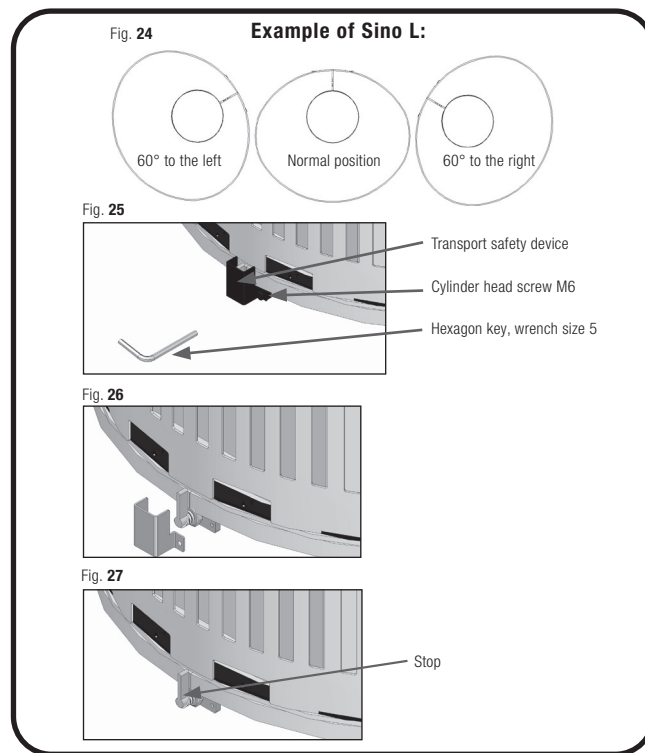

3.4 OPERATION OF THE WATER HEAT EXCHANGER SENSO M H₂O / PIKO H₂O

Operation of the water heat exchanger is done with the lever on the right side on the back (see figure). This switches between heating-up/refuelling and combustion. Intermediate positions of the lever are not provided.

This allows the stove to rotate by 90°, i.e. 45° each to the left and to the right (fig. 24).

Senso M H₂O

Heating-up and combustion phase: The lever is at the top **(A)**. The flue gases are not passed through the heat exchanger of the Senso M H₂O. Therefore, the chimney draught can develop quickly and effectively.

Combustion position: The lever is pushed all the way down **(B)**. Now all flue gases are passed through the water heat exchanger of the Senso M H₂O. This position should only be chosen when the stove has fully heated up, the fuel has started burning fully and embers have formed. Normally, this happens after about 15-20 minutes.

Piko H₂O

Heating-up and combustion phase: The lever is at the bottom **(A)**. The flue gases are not passed through the heat exchanger of the Piko H₂O. Therefore, the chimney draught can develop quickly and effectively.

Combustion position: The lever is pushed all the way to the top **(B)**. Now all flue gases are passed through the water heat exchanger of the Piko H₂O. This position should only be chosen when the stove has completely heated up, the fuel started to burn and embers have formed. Normally, this happens after about 15-20 minutes.

For better performance of the Senso M H₂O / H₂O Piko, wood should be refilled in time in order to avoid an excessive drop in the flue gas temperature.

4. COMBUSTION

4.1 INITIAL COMMISSIONING

The stove must only be installed and set up by a specialised company. The initial commissioning must only be executed by an expert employee of the

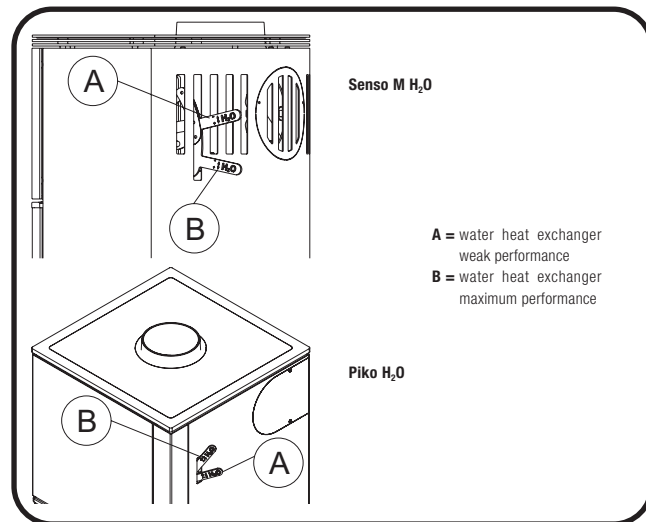

installation company. A certificate confirming proper installation and proper adjustment / function of all control components and safety components must be given to the owner / operator of the system (see „10. Commissioning protocol“ on page 46). When first putting your appliance into service, only start a moderate fire. This enables you to avoid cracks in the combustion chamber covering (which may still contain residual humidity before the first firing). Slowly increase the heating power to about 30% above nominal heat output by setting the fire 3 to 5 times to give the corrosion coating applied to the surfaces time to 'burn in' properly. The paint can be slightly soft during this process, please do not place any objects on the stove and do not touch your device. During this burning-in process, an unpleasant odor (sometimes accompanied by the build-up of smoke) may appear. Ensure the provision of good room ventilation for this burn-in process. Open all doors and windows to the outside of the building.

Initial commissioning of Senso M H₂O / Piko H₂O

The initial commissioning must only be executed after all necessary components are connected and all necessary safety devices are integrated and functional, the water heat exchanger is filled and the system has been ventilated. Operation without water, when only partially filled or when safety devices are not functioning is not permitted! During initial commissioning of the water heat exchanger, it may be necessary to vent this several times.

Moreover, the owner must be instructed in detail concerning the operation, function and maintenance of the overall system, including all supplemental components. In addition, the measures for maintaining safe operation of the system must be communicated to the owner. The executed instruction must be documented in the commissioning protocol (see „10. Commissioning protocol“ on page 46.). The installation and operating instructions must always be kept in the vicinity of the Senso M H₂O / Piko H₂O where they can be easily accessed.

Contaminated condensate exiting the combustion chamber liner may contaminate/damage the base unit. Here an absorbent pad should be placed under the unit for the first burn-ups until condensate no longer emerges. Before commissioning, check to ensure there are no objects in the combustion chamber/in the ash drawer. These must be removed. During heating and cooling, metallic grinding noises may be heard as the components of your stove expand or contract. These are completely normal and arise as a result of material expansion caused by the high temperatures.

4.1.1 COMBUSTION AIR REGULATION

Combustion air is regulated across an infinitely variable range using the actuating lever located under the door. Adjustment takes place with the fire door closed!

Air supply opened (A): For heating-up or for adding more firewood, move the actuating lever fully to the right. The combustion chamber will now be supplied with the maximum amount of air for primary and for secondary combustion purposes.

Throttled combustion (B): leave the setting lever in a near-central position. The primary combustion air supply is now closed, ensuring that the fire is not supplied with too much air. Secondary air is diverted across the ceramic viewing glass to prevent it from sooting up. This is the default position while a fire is burning. The precise position depends on local conditions and can be adjusted by the operator to reflect the combustion characteristics of the stove.

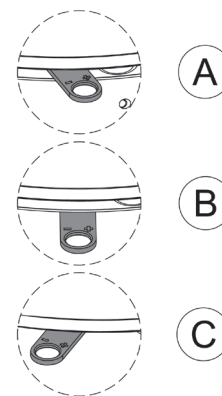

Air flow closed (C): actuating lever at far left. The combustion chamber of the stove receives no combustion air in this setting. However, do not shut down the air supply altogether until the fuel has burned away completely. If the fireplace is not in operation, you should always close the air supply.

4.2 HEATING-UP / FIRING

Lighting your stove is very easy if you follow the instructions below. We recommend the so-called upper burn-up because it is low-emission and causes less smoke and therefore less dirt in the combustion chamber and on view pane.

1. The stove must only be fuelled with correctly inserted combustion chamber liner.
2. Move the combustion air regulator to position "heating up" (A) and open the fire door (swing open).
3. Place two split logs into the combustion chamber and place smaller softwood kindling.



Fig. 28

4. Place commercial firelighter cubes on the wood to assist with igniting the fire. (Paper is not recommended because it burns too quickly and causes ash flight).
5. Methylated spirits, gasoline, oil or other readily flammable liquids must not be used.
6. Light the fire at the firelighter cubes and leave the fire door open about 3 - 5 cm. The fire should now ignite brightly and burn intensely.
7. When the kindling is burning well, add smaller hardwood logs or larger softwood logs in layers.
8. Once the firewood is burning well, close the door; actuating level remains in right-hand position (air supply open), this should usually stay in that position for 10 - 20 minutes to bring the fireplace insert up to operating temperature.
9. For more details about the correct wood feed quantity, see the section Wood feed quantity per hour ("4.2.2 Wood feed quantity per hour").
10. Once the wood has started burning fully, wood can be added as required (ideal hardwood).
11. Depending on the weather conditions, set the actuating lever to approximately the centre position. This always depends on experience and on prevailing conditions on location.
12. Do not open the door forcefully or gases may enter your living room through a suddenly produced negative pressure. At first, open the door slowly and only a bit.

13. Putting fresh firewood onto hot embers you prevent the possible release of smoke when the door is opened.
14. Never repeatedly put more than the recommended amount onto the fire.
15. If your chimney "draught" is too strong, the fire blazes strongly even if only slight secondary air is supplied. Find the optimal position for controlled combustion by shifting the controller. The further you slide the air controller towards 'Air inlet closed', the less air you are directing into the combustion chamber. Ensure that you do not restrict the airflow too far, causing the fire to go out ("4.3. Controlling heat output").

4.2.1 ADDING WOOD

Fuel can only be added when the fuel has been burned down to embers.

1. Open the air intake completely.
2. Open the fire door very slowly (use heat protective glove!), so that no turbulence can arise that favours smoldering.
3. Place the wood logs on the embers (bark facing upwards, cut ends to either side). Make sure that the air supply is open! Embers must not be smothered).
4. Close the fire door (Use a heat-resistant glove!)
5. The actuating lever should remain fully open for 2-5 minutes. Only change this position of the actuating lever once the wood has started burning fully. Then, set the actuating lever in approximately the centre position.

The end of the burning process is achieved when the wood has burned completely, and no smoldering or incomplete combustion can occur. Now the lever can be closed. If the stove is not in operation, then always move the regulator to the position air supply closed.

4.2.2 HOURLY WOOD FEED QUANTITY

In order to avoid damage due to over-heating (discolouration of the steel, deformation, etc.) and to guarantee optimum performance over the lifetime of the appliance, ensure that the stove is fuelled in the proper manner. To prevent any risk of over-heating, make sure that the maximum heating capacity is never exceeded.

The proper amount of wood feed per hour can be found in the technical data. The individual wood logs should be no more than 25 cm in circumference!

Please note: Larger feed quantities lead to overheating and damage to the stove. Wood pellets (briquettes) have a higher heating capacity than hardwood. The hourly feed rates are therefore to be kept 20% less than with wood logs. In the event of damage caused by overheating (an excessively high hourly feed rate), we shall decline all warranty claims.

4.3 CONTROLLING HEAT OUTPUT

Heat output is controlled by regulating the amount of fuel being added. Do not try to slow down combustion excessively by reducing the flow of inlet air. When heating with wood, this causes incomplete combustion and therefore wastes fuel and causes unnecessary levels of environmental pollution because wood releases gases even if no flames are produced. Incomplete combustion also leads to increased soot accumulating on the pane! In addition, there is the risk of a deflagration (explosive ignition of flue gases). Ensure that the firebox door is always firmly closed to prevent combustion being accelerated by the uncontrolled inflow of air. The performance of your stove is also dependent on the draught in your chimney. This draught can be adversely affected by the cross section of the chimney, or by environmental factors such as strong winds etc.

4.4 ROOM HEATING CAPACITY / INDOOR CLIMATE

The room heating capability used to be quoted in accordance with the DIN 18893 standard (most recent edition being August 1987) so is no longer a meaningful indicator for modern houses constructed after 1990. As a comparison value, or for use on older housing stock that fails to comply with the thermal insulation standard of 1977, the old indication of room heating capability may still be of interest.

Precise descriptions of the terms 'favourable', 'less favourable' and 'unfavourable' can be found in DIN 18893. The simplified description 'favourable' applies to the case, where the room under consideration only has one external wall and the remaining walls are adjacent to heated internal areas of the building, "unfavourably" on the other hand is based on two exterior walls and adjacent unheated rooms. The values given refer to building fabrics that do not yet meet the requirements of the Heat Insulation Ordinance of 1977. They represent a simplification which is valid for a room with a maximum size of up to 200 m³. Even in room sizes larger than 200 m³, the DIN 18893 standard recommends a calculation in accordance with DIN 4701. Nowadays, room heating capacity estimates are made in accordance with TROL guidelines and more detailed calculations in accordance with DIN 12831.

4.5 HEATING IN THE SHOULDER SEASONS/DURING UNFAVOURABLE WEATHER CONDITIONS

In the transitional period, when outdoor temperatures are above about 15°C or under unfavorable conditions (katabatic winds, etc.) disturbances in the chimney draught during a sudden temperature may rise, so that the hot gases are not completely removed. To prevent this, less fuel should be used and the air supply should be open („4.1.1 Combustion air regulation“ on Page 29). This allows more flame to develop, burns the fuel more quickly and stabilises the draught. In order to prevent the build up of ash, the fire should be stoked more frequently. Once the chimney draught has stabilised, the supply air setting can be reduced. Once the chimney draught has stabilised, the air supply can be restricted slightly (near the centre position).

4.6 CHIMNEY FIRE

The combustion of wood (especially coniferous wood) will cause sparks to travel from the fireplace into the chimney. This may ignite the soot in the chimney. (this rarely happens if the chimney is cleaned regularly by the chimney sweep). The chimney catches fire. This can be recognized by flames that blaze from the chimney opening, excessively flying sparks, smoke and odors, as well as the chimney walls becoming progressively hotter. It is important to act properly in such cases. You can alert the fire brigade by dialling 999 (or 112 in Germany). The chimney sweep must also be informed. Combustible objects should be located away from the chimney.

Attention: Do not attempt to extinguish the fire with water before the fire brigade arrives on the scene. Temperatures in a chimney fire can reach up to 1300°C. Extinguishing water would immediately create steam. A 10-litre bucket of water yields 17 cubic meters of steam. The enormous pressure created as a result could cause the chimney to disintegrate. After the chimney has burned out, this is to be examined by an expert for cracks or leaks and to be repaired if necessary.

5. FUEL

Only those fuels listed in the BImSchV (German Federal Emissions Protection Ordinance) may be burned in stoves. Only wood logs (recommended residual moisture of 20% or less) or wood briquettes according to DIN 51731 are permitted for stoves. Incidentally: A measuring instrument for determining the moisture content of firewood is cheap and it quickly pays for itself.

Do not use any other fuels!

What follows from this that it is not permitted to burn:

- painted or plastic-coated wood
- Fibreboard or wood that has been treated with timber preservative
- Wood that comes from Euro pallets

- Rubbish, household waste, old clothes
- Paper, paper briquettes, cardboard
- Coal, coal briquettes, lignite
- Damp wood (residual humidity > 25%)
- Plastic or foam of any kind
- any solid or liquid materials that contain no wood

It is prohibited to burn these or other inappropriate materials in your stove. When burning other materials than the permitted fuels, wood logs or wood briquettes defined in DIN 51731, toxic gases can be formed that have an adverse effect on the combustion process, and that may even cause explosions.

Operating stoves with unapproved types of fuel will cause the warranty and approval to become null and void!

Use small bits of wood for beginning to heat. For firewood, use only split wood that is not thicker than about 8 cm at its thickest point. The optimum length is approximately 25 cm. Please do not add too much wood at one time. Instead, it is better to add smaller quantities of wood at regular intervals. When adding fuel, the embers must not be completely covered.

5.1 CO₂ NEUTRALITY

Wood only emits as much carbon dioxide as it had previously incorporated when it was a living tree. It is immaterial whether the wood burns or rots in the forest – the carbon dioxide output always remains constant. This creates a closed natural carbon cycle.

Conclusion: When burning wood, nature remains in balance. German Law legislates for the sustainable management of forests. This obligation leads to an increase in timber volumes, since the average increase in timber is 40% greater than the amount of firewood and timber that is consumed.

5.1.1 WOOD STORAGE

Usually, it is recommended to store firewood protected against moisture in a well ventilated storage facility for approximately 2- 3 years (e.g. under a roof overhang facing away from the weather side). When properly stored, a wood moisture level < 20% is achieved more quickly.

Therefore, you should store your firewood split, because the bark prevents the moisture from escaping. To ensure good ventilation, you should leave a hand gap distance between the logs, so that air can circulate freely and so escaping moisture can be well absorbed by the air. A gap of about 20-30 cm to the ground should be maintained below the log pile. The re-absorption of moisture due to precipitation (e.g. rain or snow) should be avoided. The storing of wood in garages, under plastic sheets or in poorly ventilated basements is not recommended, because then the moisture existing in the wood has difficulty to escape.

5.2 YOUR CONTRIBUTION TO ENVIRONMENTAL PROTECTION

Whether or not your stove burns in an environmentally-friendly way is very much dependent on the choice of fuel and the manner, in which the fire is operated. The following tips should help you operate your stove with minimum harm to the environment.

- Use as little wood containing resin as possible (fir, pine, spruce). These types of wood cause soot to form on the window of your stove more rapidly, and also cause more sparks. Therefore, for safety reasons, only use deciduous woods (birch, beech, oak, fruit tree timber).
- Adapt the amounts of wood you add to the fire to suit your heating requirements.

You can check that combustion in your stove is clean and relatively free of pollutants in the following way:

- The ash should be white. If the ash is dark, this indicates the presence of residual carbon, which in turn indicates incomplete combustion.
- The flue gases in the chimney top should be almost invisible (the less visible the flue gases, the better the combustion).
- The firebox lining in your stove should be bright after combustion, not sooty.

Note: The fireplace must not be used as a waste incinerator! This is a temporary fire area thus, longer continuous burning is not achieved by piling up the fire repeatedly. Continuous burning without piling up the fire in-between cannot be achieved even through withdrawal of the combustion air and is not permitted.

6. CLEANING AND CARE

The stove may only be cleaned when cold. Bear in mind that through cleaning, contamination of the setup room and the clothing worn can occur. We recommend that you to the protect the area around the combustion chamber opening with foil or a cloth against dirt and to wear work clothes. After cleaning, all removed parts should be refitted.

6.1 CLEANING THE COMBUSTION CHAMBER/CLADDING PARTS

- The stove, the combustion chamber, the smoke collecting chamber with the heating gas diverter, the combustion air supply and the connecting pieces to the chimney must inspected at regular intervals for deposits and cleaned if necessary annually, possibly also during and after each heating season and after cleaning the chimney (consult your stove dealer or chimney sweep). Use a hand brush and/or an ash vacuum (specialty traders) to remove the debris. The chimney should be cleaned at regular intervals by chimney sweeps! Furthermore, the stove should be checked annually by a specialist.

- Gas flue deflector: a gas flue deflector is also located above the combustion chamber in the flue gas manifold. This must be cleaned regularly. The flue gas deflector can be removed for this purpose. This must be raised, then tilted and removed through the combustion chamber. The deposits on the deflector can be easily removed with a hand brush.
- Ash removal: Your stove is suitable for burning dry wood that burns best in its own ashes. However, if you want to remove the ash from the combustion chamber, open the fireplace door. Lift the grates out of the combustion chamber and brush (using standard fire irons) the ashes in the ash drawer underneath. Then remove this to dispose of the contents properly.
- Please note that the embers can remain hot up to 24 hours or more!
- Cleaning of ceramic glass pane: You can easily clean the glass panel with a commercially available cleaning agent for fireplace glass. Use dry cloth to wipe. No scouring. Please do avoid that excess cleaning agent enters between door frame and glass panel. This might cause the hardening of the sealing compound between glass panel and door frame. A hardened sealing compound might lead to damages of door and glass. Suitable cleaning agents for fireplace glass are available at your specialist dealer.
- Painted surfaces and the cladding parts can be cleaned with a moist cloth (do not use a microfibre cloth!) without cleaning agent.
- Glass surfaces can be cleaned with a standard glass cleaner and a soft cloth (do not use a microfibre cloth!).
- Stainless steel surfaces can be cleaned with standard stainless steel cleaner. Only use in the direction of the finish!
- Natural stone surfaces can be cleaned with a damp cloth or appropriate commercial cleaners!
- Ceramic surfaces can be cleaned with a damp cloth or appropriate commercial cleaners!

During the hot season, remove any dust on and below the stove furniture regularly as dust particles can burn or char. This can cause dirt in the room and on the furnishings where the fire is installed or to odorous annoyance.

6.2 COMBUSTION CHAMBER LINING

During the heating-up phase, it is normal for the liner to have a dark lining. Once the operating temperature is reached, the combustion chamber lining will be burned off. Cracks are not necessarily grounds for a justified complaint. The lining is exposed to very high loads. A tension or expansion crack is not a matter for concern and is not a functional deficiency. However, cracked and combustion chamber lining parts that have changed position must be replaced. If replacement fireclay is needed, it can be ordered from specialist suppliers. We provide the corresponding fireclay plans and order numbers in the media portal (www.spartherm.com).

6.3 MAINTENANCE

The door seal should be checked regularly. This seal must be replaced if necessary (in case of wear, breakage, etc.). The combustion chamber liner is made of natural products and must therefore be checked at regular intervals.

As long as the combustion chamber liner maintains the position in the combustion chamber and does not break, it is fully functional. A crack in the fireclay brick is therefore no need for a complaint. To ensure proper functioning, it is essential that an annual (if possible before the heating season) maintenance of the stove be carried out by a specialist!

Furthermore, the following applies to room air independent stoves:

Proper door seal is an essential item for room-air-independent operation of the stove. Check the seal for optical characteristics (pressure, wear, bulges) at least once per heating season and replace it immediately if damaged.

The fireplace must never be modified! Only original spare parts that have been approved by the manufacturer may be used! If you have any questions, please contact your specialist dealer.

6.3.1 LUBRICATION MANUAL FOR DOOR LATCHES WITH SMARTCLOSE

Stoves with SmartClose door locking mechanisms must be lubricated at regular intervals to assure problem-free operation (once per heating season). For this purpose, the scope of delivery of each fire area includes a tube of special stove lubrication compound.

This lubricating compound is applied to facilitate ease of movement of heavy fire doors, and to prevent noise caused by opening and closing those fire doors. The lubricating compound must be applied at least once a year to the spring connection on the SmartClose and its associated roller. With fire areas used frequently or very frequently, it may be necessary to shorten this lubrication interval. Depending on the type of stove, the door lock springs may be located below and/or above the fire door. In order to lubricate the lock, you may use a standard cotton swab/Q-tip as an aid.

To apply the lubricant compound, proceed as follows:



Open and secure the fire door; Apply a little lubricant compound to the cotton swab (see Fig. 1) and use it to coat the spring support on the door lock; Turn the locating roller on the body of the stove during this application process (see Fig. 2). Open and close the fire door a few times and, if necessary, apply the lubricant compound once again.

Caution: Ensure that no copper lubricant compound makes contact with cladding parts or similar items! Remove dirt and grime straight-away with a cotton cloth. Never operate the equipment during intervening periods.

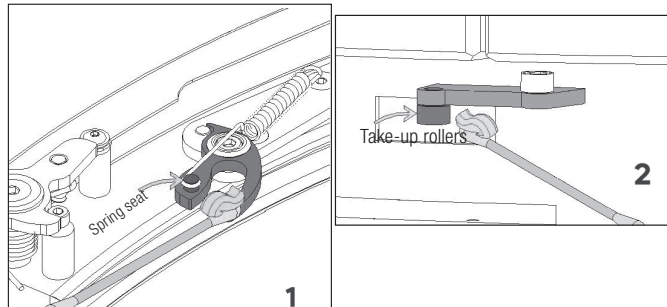

6.3.2 MAINTENANCE OF THE WATER HEAT EXCHANGER SENSO M H₂O / PIKO H₂O

Maintenance of Senso M H₂O / Piko H₂O is essential. The Senso M H₂O / Piko H₂O can only function at full efficiency if it is regularly and properly serviced. The technical heating inspection and checking of all safety devices (thermal discharge safety device, safety valve, etc.) and of the other components, such as the pump thermostat, is required yearly before the heating season. The inspection must be carried out by a specialist company. We recommend that you conclude a maintenance contract with your specialised company. The annual safety inspection is carried out reliably before the heating season. All annual safety inspections must be documented!

6.3.3 VENTING THE WATER HEAT EXCHANGER SENSO M H₂O / PIKO H₂O

SENSO M H₂O

The vent is located behind the upper cladding door. The bleeder can be opened with the supplied bleed key.

Bleeding the system:

- Before commissioning and again after the first operating days.
- If noises (air bubbles) can be heard in the heat exchanger.
- When the pressure in the domestic water supply has been adjusted

Piko H₂O

The bleeder is located under the ash drawer in the lower compartment. The bleeder can be opened with the supplied bleed key. There should be an appropriate collecting vessel or a large cloth kept ready for collecting the escaping water. A small tube can also be inserted on the bleeder. When opening the valve, water initially emerges from the bleed line and then air after a few seconds. After the air has escaped, leave the valve fully open for a further five seconds.

Bleeding the system:

- Before and during initial commissioning
- Bleed it daily until there is no air during the subsequent weeks.
- If noises (air bubbles) can be heard in the heat exchanger.
- When the pressure in the domestic water supply has been adjusted.

6.4 CLEANING THE WATER HEAT EXCHANGER SENSO M H₂O / PIKO H₂O

Cleaning the water heat exchanger is essential. With regular and proper maintenance, the stove can deliver its full potential. Cleaning must always be executed in cooled-down status!

The water heat exchanger should be cleaned once daily, or each time the ash drawer is emptied, once it has cooled down. Regular operation of the cleaning system prevents the system from seizing.

If after the first cleaning operations, it is noticeable that little to no deposits were removed, this means that you can extend the cleaning interval for your operating conditions. If, on the other hand, heavy deposits are found during cleaning, then cleaning must be carried out more frequently and the cleaning interval must be shortened.

If the cleaning mechanism can only be operated with increased force after prolonged operation, this is an indication of disproportionate contamination of the water heat exchanger. In this case, please check the moisture content of the fuel (< 20 %) and make sure that the heating integration works properly (min return temperature > 62°C). If you are not sure that these conditions have been complied with, please contact your installer for heating installations. When inserting the operating handle, ensure that it does not hit the painted edges! The soot discharged by cleaning automatically falls onto the baffle plate in the combustion chamber and should be cleaned off from there at least 2 times per season.

SENSO M H₂O

Because the water heat exchanger cools down the flue gases of the Senso M H₂O, and this unavoidably results in deposits on the surfaces of the heat exchanger, these surfaces must be cleaned with the provided brush on a regular basis.

The water heat exchanger is cleaned through the cleaning opening. To do this, open the upper cladding door and remove the cap by removing the wing nuts. Now the heat exchanger surfaces are exposed and can be cleaned with the supplied cleaning brush. The assembly occurs in the reverse order: First put the cap on the cleaning opening and re-attach the wing nuts.

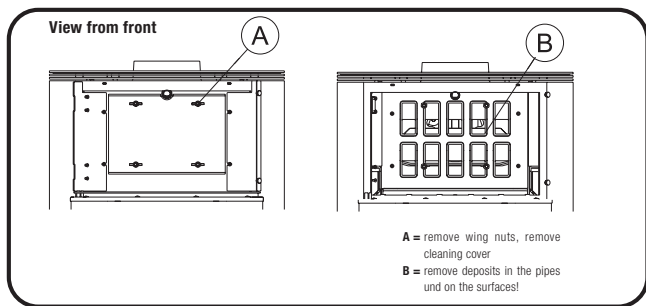

Piko H₂O

Because the water heat exchanger directly cools down the flue gases of the Piko H₂O, and this unavoidably results in deposits on the surfaces of the heat exchanger, these surfaces must be cleaned with the provided brush on a regular basis.

The operating handle of the cleaning mechanism is included in delivery and must be inserted in the 20mm hole on the top left side of the unit when cleaning. After inserting it, it must be twisted about 5 times to the right and left to the stops (approximately 20° angle of rotation).

7. TROUBLESHOOTING

Problem	Cause, explanation	Chapter note	Solution
Glass becomes sooted heavily, rapidly and unevenly.	You did not use the correct combustion materials.	5.	Use natural, bulky bits of timber compliant with 1st BImSchV §3 (German legislation).
	The ambient temperature is above about 15°C. The weather conditions are unfavorable (e.g. fog). These weather conditions occur most frequently in spring and fall.	4.5	Fill the fireplace with a small amount of fuel and light it with the damper fully open (max. air flow).
	There is a temperature inversion. That means that the upper layers of the atmosphere are warmer than the lower layers.	4.5	Fill the fireplace with a small amount of fuel and light it with the damper fully open (max. air flow).
	The combustion air controller is not fully opened.	4.1.1	Move the air actuating lever into its far right-hand position.
	The external combustion air line is not free.	2.2.2.2	Clean the combustion air line.
	Combustion air is too heavily restricted. This means that soot accumulates quickly, within just half an hour. (it is normal for the fireplace unit to become progressively dirtier from operation of the system. When driving, a car window becomes dirty, too!)	-	Check the position of the air lever and, if necessary, open up the combustion air flow rate fully to bring the fireplace unit up to operating temperature.
	The seating of a gasket is not perfect.	-	Check all seals, e.g. open the fire door and press the seal fully into the door profile.
	The wood is not dry enough.	5.	Measure the residual humidity in the wood used with a humidity detector. The recommended residual humidity is 20% or less.
	Not enough wood has been added. (an insufficient amount of wood can result in temperatures in the stove not being high enough).	4.2.2	The proper amount of wood feed per hour for your tiled stove can be found in the technical data.
	The chimney draught is too strong / too weak.	-	Observe the situation. The draught characteristics can be affected by the prevailing weather pattern. If the glass continues to soot up badly, inform your chimney sweep.
Fire is difficult to ignite	You did not use the correct combustion materials.	5.	Use natural, bulky bits of timber compliant with 1st BImSchV §3 (German legislation).
	The wood is not dry enough.	5.	Measure the residual humidity in the wood used with a humidity detector. The recommended residual humidity is 20% or less.
	The wood too thick.	5.	Use small-sized timber to light the fire. For firewood, use only split wood that is not thicker than about 8 cm at its thickest point. The optimum length of firewood is approximately 20 - 25 cm. In the case of prolonged heating, do not add too much wood. Instead, it is better to add smaller quantities of wood.

Problem	Cause, explanation	Chapter note	Solution
Fire is difficult to ignite	A sufficient air supply is not assured.	4.1.1	For lighting the fire or adding more firewood, move the actuating lever fully to the right.
	The ambient temperature is above about 15°C. The weather conditions are unfavorable (e.g. fog). This is referred to as an intervening period.	4.5	Fill the fireplace with a small amount of fuel and light it with the damper fully open (max. air flow).
	There is a temperature inversion. That means that the upper layers of the atmosphere are warmer than the lower layers.	4.5	Fill the fireplace with a small amount of fuel and light it with the damper fully open (max. air flow).
	The combustion air controller is not fully opened.	4.1.1	Move the air actuating lever into its far right-hand position.
	The external combustion air line is not free.	2.2.2.2	Clean the combustion air line.
	The chimney is not unobstructed.	-	Inform the chimney sweep.
	There is not enough vacuum in the chimney.	-	Light a small fire in the fireplace, following advice from your fireplace installer or chimney sweep.
Smoke escapes when adding wood	Air-extracting equipment is switched on, e.g. kitchen extractor fan.	-	Ensure that all air-extracting equipment is switched off.
	Wood added prematurely, on top of unburned wood.	4.2.1	Do not add fresh firewood until there is a bed of hot embers in the combustion chamber.
	The chimney is not unobstructed.	-	Inform the chimney sweep.
	Your fireplace has not already reached its operating temperature.	-	Burn down remaining wood until it forms a bed of hot embers, then add smaller pieces of firewood.
	The door has been opened too wide.	4.2.1	Open the door slowly and carefully.
Combustion too fast / wood consumption too high	The diameter of your stack of wood is too small.	4.2.2	The ideal diameter for a stack of wood is about 25 cm.
	The chimney draught is too strong.	-	Inform the chimney sweep. Perhaps increase combustion air flow to counteract choking action.
	The combustion air flow has not been reduced.	4.1.1	Leave the actuating lever in about its center position.
	Ever since the lighting the fire, the fire door has been slightly open.	-	Close the fire door!
	The recommended wood feed quantity has not been observed.	-	The proper amount of wood feed per hour for your tiled stove can be found in the technical data.

7.1 WATER HEAT EXCHANGER SENSO M H₂O / PIKO H₂O

Thermal discharge safety device trips constantly (constant water out-flow through the discharge). The water heat exchanger cannot dissipate heat to the heating system.

- The buffer tank is "full" → Remove heat from the tank.
- Check function and settings of the pump thermostat and the return flow boost.
- Set the pump one level higher (higher flow rate).
- Circulation pump does not run. Power connection defective?
- Venting the the stove:
- Check system pressure.

During first usages, water escapes in the field of garden soil.

If the stove and the heating systems was tested under pressure after installation, the water discharged is condensate from the fuel and the combustion chamber liner. If more than 0.2 litres of water accumulate, then the heating system pressure must be tested.

Gurgling noises in the water heat exchanger.

- Air in the system, check the system pressure.
- Ventilate system via the vent. For newly filled or topped up systems it takes some time for all the air to collect. Often ventilating once does not suffice.

Thermal discharge safety device drips.

- Flush the thermal discharge safety device by activating the red button on the fitting.
- Check the seat of the connection seals and the piston (see the manual thermal discharge safety device).
- If necessary, integrate filter in the system upstream of the discharge safety device (pay attention to the minimum flow rate!)

Radiators do not warm up. Radiators that are not located in the installation room are cold.

- Close radiator thermostats when the set room temperature is reached. The convection heat of the fireplace is distributed in the air composite.
- Depending on the configuration the heating system is sluggish. It takes some time until the heating system dissipates its heat.
- Have the heating system hydraulically calibrated.
- Check that the heating circulation pump is functioning.
- Increase the amount of fuel.

Increasing and faster contamination of the combustion chamber lining and of the glass ceramics. The combustion chamber lining no longer burns free. Fire can only be ignited with difficulty

- Remove deposits in the heat exchanger and in the connecting line to the chimney. Remove deposits in the heat exchanger and in the connecting line to the chimney.
- Check that the pump thermostat is functioning properly.
- Pay attention to correct firing, wood feed quantity, wood moisture content < 20%.
- Correct the position of the air control lever.
- Check that the return riser is functioning properly.

Fast contamination of exhaust gas flue in the water heat exchanger. Inadequate fire behaviour.

- Check the return riser.
- Pay attention to correct firing, wood feed quantity, wood moisture content < 20%.
- Remove deposits in the heat exchanger and in the connecting line to the chimney. Remove deposits in the heat exchanger and in the connecting line to the chimney.
- Check that the pump thermostat is functioning properly.
- as a result of thermal loading.

8. DISASSEMBLY

8.1 SAFETY INSTRUCTIONS FOR DISASSEMBLY

⚠ WARNING! Danger due to non-observance of the disassembly instructions!

Mistakes made when dismantling the unit can result in serious injury. This chapter contains important information for the safe disassembly of the unit.

- Read this chapter carefully before disassembly.
- Follow the safety instructions.
- Carry out the disassembly as described.

Dismantling only by qualified personnel. Electrical work only by qualified electricians.

To avoid hazards, it is essential to comply with the following requirements:

- The appliance and other touchable parts have cooled down for a sufficiently long time (e.g. several days).
- There is no heat or embers in the combustion chamber.
- The surroundings of the stove are protected, e.g. by covers for floors and furniture.

Before dismantling, the appliance and the stove system must be cleaned. For the cleaning work, the baffle plate is removed from the combustion chamber.

8.2 DISMANTLE UNIT

- Remove all connections and joints between the stove unit and the chimney.
- Dismantle all pipes from the flue gas duct.
- If present, dismantle all pipes from the combustion air duct.
- For hydronic units, remove all connections between the stove system and the heating system
- Dismantle all pipes from the water connections.

9. DISPOSAL

9.1 DISPOSE OF PACKAGING

⚠ ATTENTION! Risk of environmental damage due to improper disposal of the packaging!

- Do not dispose of the packaging in normal household waste.
- Dispose of the packaging in an environmentally friendly and appropriate manner (recycling)

The packaging serves to protect against transport damage. The packaging materials are selected according to environmentally compatible aspects and are made of recyclable materials. The packaging materials can be returned to the raw material cycle after use. Dispose of the packaging in an environmentally friendly manner, separated according to materials.



9.2 DISPOSE OF THE APPLIANCE

⚠ ATTENTION! Risk of environmental damage due to improper disposal of the unit!

- Do not dispose of the appliance in normal household waste.
- Dispose of the appliance in an environmentally friendly and appropriate manner (recycling).

Dispose of the appliance in accordance with the legal regulations via a specialist disposal company or your municipal waste disposal facility.

10. APPENDIX

10.1 ACCESSORIES

Burn-off control S-Thermatik Neo
Differential pressure sensor S-USI II

10.2 DECLARATIONS OF CONFORMITY

This product complies with the European directives in terms of design and operating behaviour. Conformity has been proven with the CE marking.

A declaration of performance in accordance with Regulation EU 305/2011 is available on the manufacturer's website: www.spartherm.com

11. TECHNICAL DATA

Stove with water-side connections

The water-side connections are located at the rear, in the lower area.

* The values given represent the average value over one combustion. These values are obtained under test conditions when a quantity of wood of approx. 2.2 kg logs is burnt every hour.

¹The thermal discharge safety device integrated into the heating system will kick in at a flow temperature of approx. 95 °C!

12. FINAL COMMENT

If required and for further information (e.g. brochures, spare parts, price lists): Contact the manufacturer or the specialist trade.
www.spartherm.com

You can find warranty conditions on www.spartherm.com

Damages and claims for compensation which are not the result of delivery of a defective appliance from Spartherm Feuerungstechnik GmbH are excluded and are not part of this warranty promise.

The above shall not include claims made in respect of statutory legal requirements.

Technical data	SENSO M H₂O	PIKO H₂O
Water heating output	approx. 5.0 kW *	4.6 kW
Perm. working overpressure	3.0 bar	3.0 bar
Max. perm. flow temperature ¹	105°C	105°C
Max. operating temperature	95°C	95°C
Minimum return temperature	60°C	60°C
Water-side resistance at 650 l/h	18 mbar	26 mbar
Minimum throughput of thermal discharge safety device	900 ltr.	900 ltr.
Water content	approx. 17 ltr.	approx. 29 ltr.

Stoves		Modell		Sento	Lungo 2L	Piko S steel	Piko S	Piko L	Piko Frame	Piko H ₂ O	Cubo S	Cubo L	
		optional		RLU	2L / 2R		RLU	RLU			RLU	RLU	
Performance data	Energy efficiency class			A+	A	A+	A+	A+	A+	A+	A+	A+	
	Nominal output		kW	6,5	6,0	5,9	5,9	5,9	5,9	5,9	7,9	5,9	5,9
	Min./max. heating capacity		kW	4,6 - 8,5	4,5 - 7,8	4,5 - 7,7	4,5 - 7,7	4,5 - 7,7	4,5 - 7,7	4,5 - 7,7	5,5 - 10,3	4,5 - 7,7	4,5 - 7,7
	Efficiency		%	80	80	80	80	80	80	80	80	80	80
	Power distribution air / H ₂ O		%	–	–	–	–	–	–	–	42 / 58	–	–
	Power distribution air / H ₂ O		kW	–	–	–	–	–	–	–	3,3 / 4,6	–	–
	Room heating capacity		favourable, approx.		186	165	144	144	144	144	56	144	144
			less favourable, approx.		107	95	84	84	84	84	35	84	84
			unfavourable, approx.		73	65	56	56	56	56	22	56	56
	Mass flow of flue gas at NW		g/s	6,0	7,3	4,9	4,9	4,9	4,9	4,9	8,6	4,9	4,9
	Flue gas temperature on the flue gas outlet		°C	301	254	325	325	325	325	325	215	325	325
	Min. supply pressure at NW		Pa	12	11	12	12	12	12	12	12	12	12
	Combustion air requirement		m ³ /h	19,7	25,2	15,4	15,4	15,4	15,4	15,4	30,5	15,4	15,4
Dust		mg/Nm ³	<40	<40	<40	<40	<40	<40	<40	<40	<40	<40	
CO		mg/Nm ³	<1250	<1250	<1250	<1250	<1250	<1250	<1250	<1250	<1250	<1250	
NOx		mg/Nm ³	<200	<200	<200	<200	<200	<200	<200	<200	<200	<200	
CnHm		mg/Nm ³	<120	<120	<120	<120	<120	<120	<120	<120	<120	<120	
Weights	Steel		kg	220	195	≥ 205	160	175	170-240	240	165	180	
	Buffer Page L/R		kg	21	21	–	–	–	–	–	–	–	
	Natural stone		kg	–	–	–	–	–	–	–	–	–	
	Ceramic		kg	–	202	–	–	–	–	–	–	–	
	Buffer tank, top		kg	38	↑ 78 → 52	–	–	↑ 40 → 51	–	–	–	–	↑ 40 → 51
Options	Flue gas pipe outlet, at top			✓	✓	✓	✓	✓	✓	✓	✓	✓	
	back			✓	✓	✓	✓	✓	✓	✓	✓	✓	
	Ash pan			–	–	✓	✓	✓	✓	✓	✓	✓	
	Rotation			–	–	–	–	–	–	–	–	–	
	Buffer tank			✓	✓	–	–	✓	–	–	–	✓	
	Separate combustion air			–	✓	✓	✓	✓	✓	✓	✓	✓	
Door closure				hinged	hinged	hinged	hinged	hinged	hinged	hinged	hinged	hinged	
Tests / Approvals	Multiple occupancy			✓ RLA – RLU	✓ RLA	✓ RLA	✓ RLA ✓ RLU	✓ RLA ✓ RLU	✓	✓ RLA	✓ RLA ✓ RLU	✓ RLA ✓ RLU	
	DIN EN 13240			✓	✓	✓	✓	✓	✓	✓	✓	✓	
	2. BImSchV. 2010			✓	✓	✓	✓	✓	✓	✓	✓	✓	
	Aachen / Munich / Regensburg Regulation			✓	✓	✓	✓	✓	✓	✓	✓	✓	
	DIBt room-air-independent			✓	–	–	✓	✓	✓	–	✓	✓	
	DIBt approval no.			Z-43.12-464	–	–	Z-43.12-320	Z-43.12-320	Z-43.12-320	–	Z-43.12-320	Z-43.12-320	
	Art. 15 a B-VG (Austria)			✓	✓	✓	✓	✓	✓	✓	✓	✓	
ecodesign 2022			✓	✓	✓	✓	✓	✓	✓	✓	✓		

Stoves		Modell	Cubo L style	Trico S	Trico S with S-Thermatik	Trico L	Trico L with S-Thermatik	Senso S	Senso M H ₀	Senso L	Senso L with S-Thermatik	
		optional	RLU	RLU	RLU	RLU	RLU			RLU		
Performance data	Energy efficiency class		A+	A+	A+	A+	A+	A	A+	A	A	
	Nominal output	kW	5,9	6,0	6,0	6,0	6,0	7,0	7,9	5,9	6,0	
	Min./max. heating capacity	kW	4,5 - 7,7	4,5 - 7,8	4,5 - 7,8	4,5 - 7,8	4,5 - 7,8	4,9 - 9,1	5,5 - 10,3	4,5 - 7,7	4,5 - 7,8	
	Efficiency	%	80	80	80	80	80	80	85	80	80	
	Power distribution air / H ₂ O	%	–	–	–	–	–	–	37 / 63	–	–	
	Power distribution air / H ₂ O	kW	–	–	–	–	–	–	2,9 / 5,0	–	–	
	Room heating capacity	favourable, approx.	m ³	144	165	165	165	165	186	56	144	165
		less favourable, approx.		84	95	95	95	95	120	35	84	95
		unfavourable, approx.		56	65	65	65	65	82	22	56	65
	Mass flow of flue gas at NW	g/s	4,9	5,7	5,4	5,7	5,4	6,1	6,2	5,2	5,5	
	Flue gas temperature on the flue gas outlet	°C	325	281,7	269,3	281,7	269,3	326	250	329	341	
	Min. supply pressure at NW	Pa	12	12	12	12	12	12	12	12	12	
	Combustion air requirement	m ³ /h	15,4	19,7	18	19,7	18	22,1	21,7	17,6	17,8	
	Dust	mg/Nm ³	<40	<40	<40	<40	<40	<40	<40	<40	<40	
CO	mg/Nm ³	<1250	<1250	<1250	<1250	<1250	<1250	<1250	<1250	<1250		
NOx	mg/Nm ³	<200	<200	<200	<200	<200	<200	<200	<200	<200		
CnHm	mg/Nm ³	<120	<120	<120	<120	<120	<120	<120	<120	<120		
Weights	Steel	kg	180	125	126	135	136	120	180	165	166	
	Buffer Page L/R	kg	–	–	–	–	–	28	–	–	–	
	Natural stone	kg	–	–	–	–	–	122 / 165	250	233	234	
	Ceramic	kg	–	–	–	–	–	–	–	–	–	
	Buffer tank, top	kg	↑ 40 → 51	–	–	–	↑ 29 → 41	↑ 29 → 41	–	–	29	29
Options	Flue gas pipe outlet, at top		✓	✓	✓	✓	✓	✓	✓	✓	✓	
	back		✓	✓	✓	✓	✓	✓	✓	✓	✓	
	Ash pan		✓	✓	✓	✓	✓	✓	✓	✓	✓	
	Rotation		–	–	–	–	–	–	–	✓ / –	✓	
	Buffer tank		✓	–	–	✓	✓	✓	✓	✓	✓	
	Separate combustion air		✓	✓	✓	✓	✓	✓	✓	✓	✓	
Tests - Approvals	Door closure		hinged	hinged	hinged	hinged	hinged	hinged	hinged	hinged	hinged	
	Multiple occupancy		✓ RLA ✓ RLU	✓ RLA ✓ RLU	✓ RLA ✓ RLU	✓ RLA ✓ RLU	✓ RLA ✓ RLU	✓ RLA	✓ RLA	✓ RLA – RLU	✓ RLA	
Tests - Approvals	DIN EN 13240		✓	✓	✓	✓	✓	✓	✓	✓	✓	
	2. BImSchV. 2010		✓	✓	✓	✓	✓	✓	✓	✓	✓	
	Aachen / Munich / Regensburg Regulation		✓	✓	✓	✓	✓	✓	✓	✓	✓	
	DIBt room-air-independent		✓	✓	✓	✓	✓	–	–	✓	–	
	DIBt approval no.		Z-43.12–320	beantragt	beantragt	beantragt	beantragt	–	–	beantragt	–	
	Art. 15 a B-VG (Austria)		✓	✓	✓	✓	✓	✓	✓	✓	✓	
	ecodesign 2022		✓	✓	✓	✓	✓	✓	✓	✓	✓	

Stoves		Modell	Senso L klassik	Senso L klassik with S-Thermetik	Senso L fashion	Senso L fashion with S-Thermetik	Sino L	Sino L with S-Thermetik	Sino City	Sino City with S-Thermetik	Moro	
		optional	RLU		RLU		RLU		RLU		RLU	
Performance data	Energy efficiency class		A	A	A	A	A	A	A	A	A+	
	Nominal output	kW	5,9	6,0	5,9	6,0	5,9	6,0	5,9	6,0	5,0	
	Min./max. heating capacity	kW	4,5 - 7,7	4,5 - 7,8	4,5 - 7,7	4,5 - 7,8	4,5 - 7,7	4,5 - 7,8	4,5 - 7,7	4,5 - 7,8	4,5 - 6,5	
	Efficiency	%	80	80	80	80	80	80	80	80	80	
	Power distribution air / H ₂ O	%	–	–	–	–	–	–	–	–	–	
	Power distribution air / H ₂ O	kW	–	–	–	–	–	–	–	–	–	
	Room heating capacity	favourable, approx.		144	165	144	165	144	165	144	165	124
		less favourable, approx	m ³	84	95	84	95	84	95	84	95	73
		unfavourable, approx.		56	65	56	65	56	65	56	65	48
	Mass flow of flue gas at NW	g/s	5,2	5,5	5,2	5,5	5,2	5,5	5,2	5,5	3,9	
	Flue gas temperature on the flue gas outlet	°C	329	341	329	341	329	341	329	341	337	
	Min. supply pressure at NW	Pa	12	12	12	12	12	12	12	12	11	
	Combustion air requirement	m ³ /h	17,6	17,8	17,6	17,8	17,6	17,8	17,6	17,8	12,5	
Dust	mg/Nm ³	<40	<40	<40	<40	<40	<40	<40	<40	<40		
CO	mg/Nm ³	<1250	<1250	<1250	<1250	<1250	<1250	<1250	<1250	<1250		
NOx	mg/Nm ³	<200	<200	<200	<200	<200	<200	<200	<200	<200		
CnHm	mg/Nm ³	<120	<120	<120	<120	<120	<120	<120	<120	<120		
Weights	Steel	kg	–	166	–	–	–	–	–	–	–	
	Buffer Page L/R	kg	–	–	–	–	–	–	–	–	–	
	Natural stone	kg	240	241	210	211	227 / 260	228 / 261	210 / 245	211 / 246	240 / 280	
	Ceramic	kg	–	–	–	–	–	–	–	–	–	
	Buffer tank, top	kg	–	–	–	–	–	–	–	–	–	
Options	Flue gas pipe outlet, at top		✓	✓	✓	✓	✓	✓	✓	✓	✓	
	back		✓	✓	✓	✓	✓	✓	✓	✓	✓	
	Ash pan		✓	✓	✓	✓	✓	✓	✓	✓	✓	
	Rotation		–	–	–	–	✓ / –	✓	–	–	–	
	Buffer tank		–	–	–	–	–	✓	✓	✓	✓	
	Separate combustion air		✓	✓	✓	✓	✓	✓	✓	✓	✓	
	Door closure		hinged	hinged	hinged	hinged	hinged	hinged	hinged	hinged	hinged	
Tests / Approvals	Multiple occupancy		✓ RLA – RLU	✓ RLA	✓ RLA – RLU	✓ RLA	✓ RLA – RLU	✓ RLA	✓ RLA – RLU	✓ RLA	✓ RLA – RLU	
	DIN EN 13240		✓	✓	✓	✓	✓	✓	✓	✓	✓	
	2. BImSchV. 2010		✓	✓	✓	✓	✓	✓	✓	✓	✓	
	Aachen / Munich / Regensburg Regulation		✓	✓	✓	✓	✓	✓	✓	✓	✓	
	DIBt room-air-independent		✓	–	✓	–	–	–	–	–	–	
	DIBt approval no.		beantragt	–	beantragt	–	beantragt	–	beantragt	–	Z-43.12-397	
	Art. 15 a B-VG (Austria)		✓	–	✓	–	✓	–	–	–	✓	
ecodesign 2022		✓	✓	✓	✓	✓	✓	✓	✓	✓		

13. COMMISSIONING PROTOCOL

Date	Device no.: (see rating plate)				
Installation company:					
Address of stove fitter					
System tested for leaks	<input type="checkbox"/> yes	<input type="checkbox"/> no			
Safety equipment checked (DAS, safety valve, MAG)	<input type="checkbox"/> yes	<input type="checkbox"/> no			
Visual inspection of the chimney system	<input type="checkbox"/> yes	<input type="checkbox"/> no			
Function check executed	<input type="checkbox"/> yes	<input type="checkbox"/> no	Sample - burn-up carried out:	<input type="checkbox"/> yes	<input type="checkbox"/> no
Only with SENSO M H ₂ O / PIKO H ₂ O			Enter temperatures between insert and return flow boost:		
Heating system ventilated	<input type="checkbox"/> yes	<input type="checkbox"/> no	Return flow temperature in	<input type="text"/>	°C
Operating pressure checked	<input type="checkbox"/> yes	<input type="checkbox"/> no	Flow temperature in	<input type="text"/>	°C
The stove operator has been instructed regarding operation of the control system and the instructions for assembly and use have been provided	Signatures				
	Installer / Operator				
Annual maintenance carried out:					
Type of work					
Name					
Date					
Signature					

IMPORTANT: Keep in a safe place!

- Store these instructions with valid and clearly dated proof of purchase and have the documents ready for our technicians in the event of service work.

We reserve the right to make alterations to the technical data contained herein and accept no liability in respect of any errors made.